

D680 Series
Proportional Control Valves
with Integrated Electronics
ISO 4401 Size 05 to 10

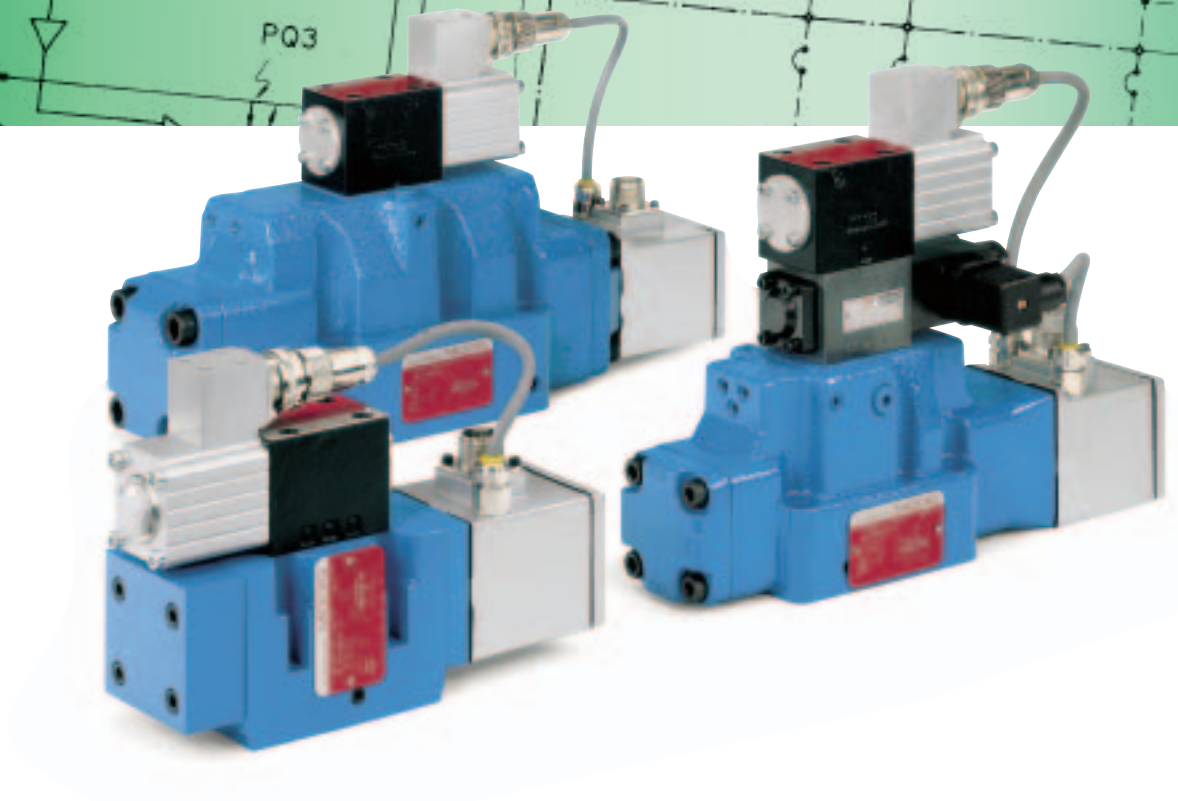

SECTION	PAGE	MOOG SERVO- AND PROPORTIONAL CONTROL VALVES
General	2	For over 50 years Moog has manufactured proportional control valves with integrated electronics. During this time, more than 200,000 valves have been delivered.
Benefits and Functionality	3	These servo- and proportional control valves have been proven to provide reliable control for injection and blow molding equipment, die casting machines, presses, heavy industry equipment, paper, lumber processing, and other applications.
General Technical Data and Symbols	4	
Function, Electronic	5	
Technical Data	8	PROPORTIONAL CONTROL VALVES, D681 TO D685 SERIES
Valve Electronics	28	The D680 Series Proportional Flow Control Valves are throttle valves for 2-, 3-, 4- and 5-way applications.
Failsafe Version	32	These valves are suitable for electrohydraulic position, velocity, pressure or force control systems, including those with high dynamic response requirements.
Input Command Wiring Schematic	40	
Ordering Information	41	With the new D633 Series directly driven pilot valve (DDV), a further important step has been made in the direction of robustness and energy saving. This linear force motor driven pilot valve is developed as a variant of the proven Moog DDV Series.
		The integrated electronics of the D680 series is also a new development featuring SMD technology, and requires 24 V DC power supply.

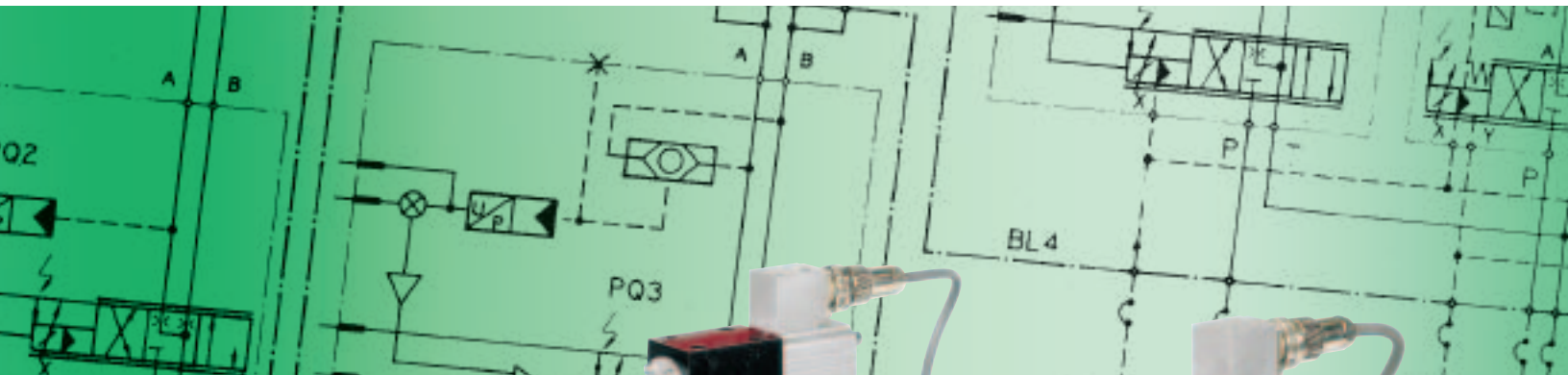

The valve series described in this catalog have successfully passed EMC tests required by EC Directive. Please refer to the respective references in the Electronics Section.

NOTICE

- Before installation of the valve into the system, the complete hydraulic system must be flushed (according to ISO 6072).
- Please read the notes in section entitled "Electronics", page 6.

Our Quality Management System conforms to DIN EN ISO 9001.

This catalog is for users with technical knowledge. To ensure that all necessary characteristics for function and safety are given, the user has to check the suitability of the products described herein. The products described herein are subject to change without notice. In case of doubt, please contact Moog Inc.

All trademarks as indicated herein are the property of Moog Inc. and its subsidiaries. Moog Inc. 2003. All rights reserved. All changes are reserved. For the most current information, visit www.moog.com/valveindex.

[Moog is registered trademark of Moog Inc. and its subsidiaries.](#)

OPERATIONAL FEATURES OF THE DIRECT DRIVE PILOT VALVE

- A direct drive pilot valve requires no pilot leakage flow. This results in considerable energy savings, especially for systems with multiple valves.
- The dynamics of the direct drive valve is nearly independent of the operating pressure.
- Reliable operation. The excellent pressure gain of the pilot valve with spool / bushing, provides high spool driving forces to the long stroke main spool. This ensures enhanced main spool position control even with high flow forces and contaminated fluids.
- Excellent dynamics based on a high natural frequency allows high main spool position loop gain, resulting in extremely good static and dynamic response of the main valve.

OPERATIONAL FEATURES OF THE COMPLETE VALVE

- Valve body for high rated flow, optional with external pilot supply using X and Y ports.
- Reduced spool drive area with D683 and D684 Series results in the following advantages:
 - improved dynamic response
 - reduction in pilot fluid flow for fast movements of the main spool.
- Failsafe versions available with defined safe spool position using a spring and a 4/2-way solenoid valve for control flow short circuit.
- The D680 series proportional control valves are of two-stage design. By combining a fast first stage, suitable main spool drive area and integrated electronics, an optimum proportional valve can be offered.

DESCRIPTION OF THE DIRECT DRIVE PILOT VALVE

The D633 Series pilot valve consists of a permanent magnet linear force motor, a drive rod connecting motor armature and the spool guided in a bushing. The linear force motor contains a coil, permanent magnets, pole pieces, an armature and a centering spring arrangement.

The 4-way spool controls fluid flow from the pressure port to one of the load ports, and also from the other load port to return. Deflection of the centering spring due to spool displacement, provides a return force for the armature.

An electric current applied to the coil of the linear force motor produces an electromagnetic flux depending on the current polarity. This electromagnetic flux is superimposed on the permanent magnetic flux in the airgaps between armature and pole pieces. This results in a polarity dependent displacement of the armature against the centering spring force.

The spool being connected to the armature by a rod shares the armature motion. Flow forces acting on the spool due to the fluid flow through the valve, and friction forces between spool and bushing due to contaminated fluid, are overcome by the force motor. The position of the spool is approximately proportional to the coil current.

OPERATING PRINCIPLE OF THE COMPLETE VALVE

The position control loop for the main stage spool, position transducer and pilot valve is closed by the integrated electronics.

An electric command signal (flow rate set point) is applied to the integrated position controller which drives the current in the pilot valve coil.

The position transducer (LVDT) which is excited via an oscillator, measures the position of the main spool (actual value, position voltage). This signal is then demodulated and fed back to

the controller where it is compared with the command signal. The controller drives the pilot valve until the error between command signal and feedback signal is zero.

Thus, the position of the main spool is proportional to the electric command signal.

PERFORMANCE SPECIFICATIONS FOR D681 TO D685

Operating pressure range

Ports P, A and B up to 350 bar (5000 psi)
 Port T see data of individual series
 Pilot pressure min. 10 bar (150 psi) over T or Y
 max. 350 bar (5000 psi)

Temperature range

Ambient -20 °C to +60 °C
 (-4°F to +140°F)

Fluid -20 °C to +80 °C
 (-4°F to +170°F)

Seal material NBR, FPM,
 and others on request

Operating fluid mineral oil based
 hydraulic fluid
 (DIN 51524 part 1 to 3)
 and ISO 11158, other
 fluids on request

Viscosity

recommended 15 to 45 mm²/s
 allowed 5 to 400 mm²/s

System filtration

Pilot valve: high pressure filter (without bypass, but with dirt alarm) mounted in the main flow and if possible, directly upstream of the valve.

Main stage: high pressure filter as for the pilot stage. In combination with a fast regulating variable displacement pump, an off-line filter is recommended.

Class of cleanliness

The cleanliness of the hydraulic fluid particularly effects the performance (spool positioning, high resolution) and wear (metering edges, pressure gain, leakage) of the valve.

Recommended cleanliness class

For normal operation ISO 4406 < 18 / 15 / 12
 For longer life ISO 4406 < 17 / 14 / 11

Recommended filter rating

For normal operation $\beta_{10} \geq 75$ (10 µm absolute)
 For longer life $\beta_6 \geq 75$ (6 µm absolute)

Installation options

any position,
 fixed or movable

Vibration

30 g, 3 axes
 with mating connector
 mounted

Degree of protection

EN60529: IP 65,
 delivered with an oil sealed
 shipping plate

Shipping plate

VALVE FLOW CALCULATIONS

The actual valve flow is dependent on the spool position and the pressure drop across the spool lands.

At 100% command signal (i.e. +10 VDC = 100% valve opening), the valve flow at rated pressure drop $\Delta p_N = 5$ bar (75 psi) per metering land is the rated flow Q_N . For other than rated pressure drop, the valve flow changes at constant command signal according to the square root function for sharp edged orifices.

$$Q = Q_N \cdot \sqrt{\frac{\Delta p}{\Delta p_N}}$$

Q / l / min = calculated flow
 Q_N / l / min = rated flow
 Δp / bar = actual valve pressure drop
 Δp_N / bar = rated valve pressure drop

The actual valve flow Q calculated in this way, should result in an average flow velocity in ports P, A, B or T of less than 30 m/s.

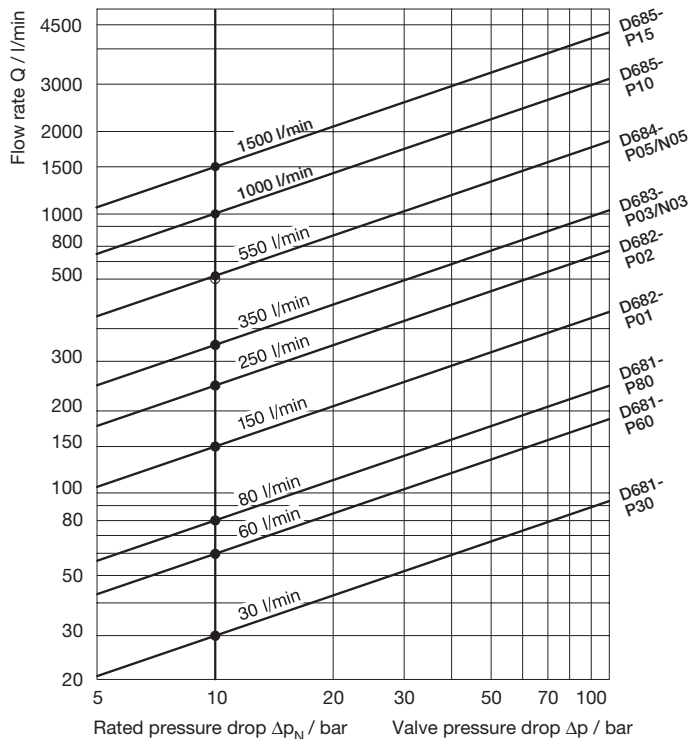

Valve flow diagram

Valve flow for maximum valve opening (100% command signal) as a function of the valve pressure drop.

D681 Series 2-stage Proportional Control Valve with D633-7... Series Pilot Valve

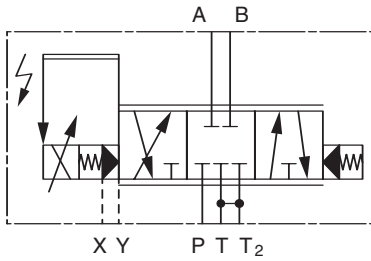

Hydraulic symbol:
Symbol shown with pilot pressure, electric supply enable signal on and zero command signal.

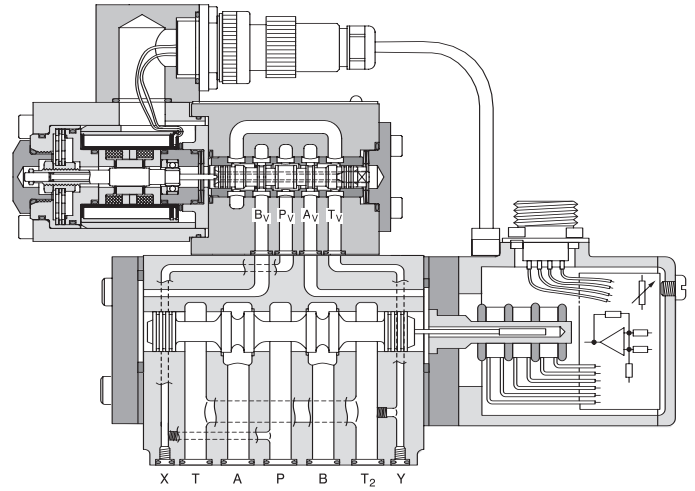

D683/4.P. Series 2-stage Proportional Control Valve with D633-7... Series Pilot Valve

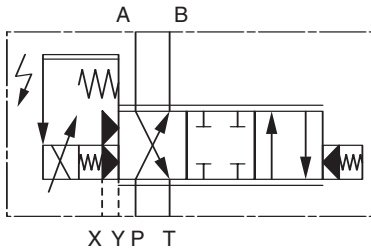

Hydraulic symbol:
Symbol shown with pilot pressure, without electric supply on enable signal off. Failsafe spool position A \uparrow T.

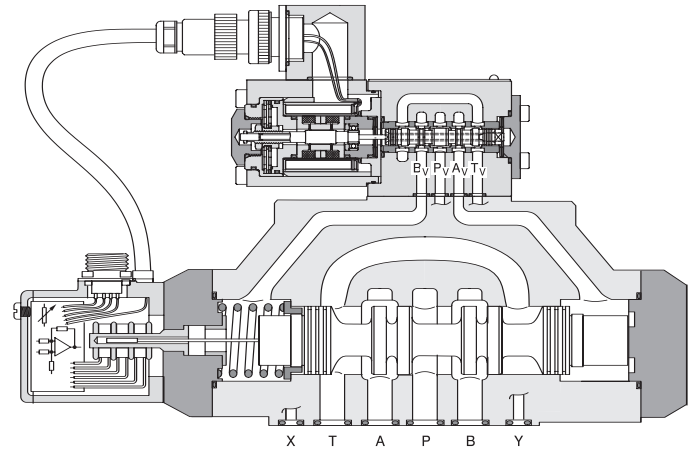

GENERAL REQUIREMENTS FOR VALVE ELECTRONICS

- Supply 24 V DC, min. 18 V DC, max. 32 V DC
Current consumption I_{max} at D68X 200 mA static
800 mA dynamic
External fuse per valve at D68X 1.0 A (slow)
- All signal lines, also those of external transducers, shielded.
- Shielding connected radially to \perp (0 V), power supply side, and connected to the mating connector housing (EMV).
- **EMV:** Meets the requirements of emission: EN55011:1998+A1:1999 (limit class: B) and immunity: EN61000-6-2:1999
- Minimum cross-section of all leads **0.75 mm² (AWG 18)**. Consider voltage losses between cabinet and valve.
- Note: When making electric connections to the valve (shield, \oplus), appropriate measures must be taken to ensure that locally different earth potentials do not result in excessive ground currents. Also see Moog Technical Note TN 353.

VALVE ELECTRONICS WITH SUPPLY VOLTAGE 24 VOLT AND 6+PE POLE CONNECTOR

**Command signal 0 to ±10 mA floating,
Valves with current command input**

The spool stroke of the valve is proportional to $I_D = -I_E$. 100% valve opening P → A and B → T is achieved at $I_D = +10$ mA. At 0 mA command, the spool is in centered position. The input pins D and E are inverting. Either pin D or E is used according to the required operating direction. The other pin is connected to signal ground at cabinet side.

**Command signal 0 to ±10 V,
Valves with voltage command input**

The spool stroke of the valve is proportional to $(U_D - U_E)$. 100% valve opening P → A and B → T is achieved at $(U_D - U_E) = +10$ V. At 0 V command, the spool is in centered position. The input stage is a differential amplifier. If only one command signal is available, pin D or E is connected to signal ground at cabinet side according to the required operating direction.

Actual value 4 to 20 mA

The actual spool position value can be measured at pin F (see diagram on the top). This signal can be used for monitoring and fault detection purposes. The spool stroke range corresponds to 4 to 20 mA. The centered position is at 12 mA. 20 mA corresponds to 100% valve opening P → A and B → T.

Circuit diagram for measurement of actual value I_F (position of main spool) for valves with 6 + PE pole connector (signal "M and X")

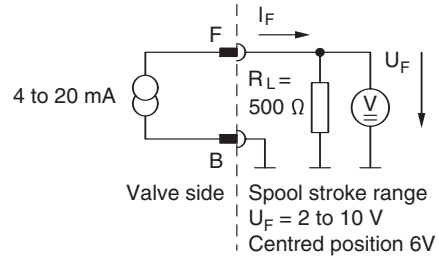

(Signal type "D" R_L integrated on electronics)

The position signal output 4 to 20 mA allows to detect a cable break when $I_F = 0$ mA. For failure detection purposes, it is advised to connect pin F of the mating connector and route this signal to the control cabinet.

Note: Enable input

With enable signal off, the main spool will move to a safe position. Spool position ± 3%.

- a) Defined centered position (Unbiased pilot valve). Function code A¹⁾
- b) End position (Biased pilot valve). Function code B¹⁾

¹⁾ see type designation

WIRING FOR VALVES WITH 6+PE POLE CONNECTOR

To EN 175201 Part 804, and mating connector (metal shell) with leading protective earth connection (\perp). Also see input command wiring schematic, Page 40 (see additional information in AM 426 E spec.).

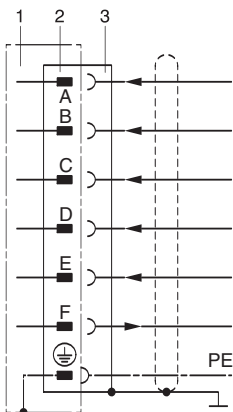

- 1 Valve
- 2 Connector
- 3 Mating connector

Function	Voltage command	Current command
A Supply	24 V DC (min. 18 V DC, max. 32 V DC)	Static: $I_{max}: 200$ mA Dynamic: $I_{max}: 800$ mA
B Supply / Signal ground	\perp (0 V)	
C Enabled Not enabled	$U_{C-B} > +8.5$ V DC $U_{C-B} < +6.5$ V DC	$I_e = 2,0$ mA at 24 V DC, max. 32 V DC (see note above)
D Input rated command E (differential)	$U_{D-E} = 0$ to ± 10 V $R_e = 10$ kΩ	Input command $I_D = -I_E: 0$ to ± 10 mA ($R_e = 200$ Ω)
F Output actual valve Spool position	Inputs for U_{D-B} and U_{E-B} for both signal types limited to min. -15 V and max. +32 V $I_{F-B} = 4$ to 20 mA. At 12 mA spool is in centred position. $R_L = 100$ bis 500 Ω Signal code D: $U_{F-B} = 2$ to 10 V. At 6 V spool is in centred position. $R_L = 500$ Ω	
⊕ Protective earth		

Additional information on command signal on page 40.

VALVE ELECTRONICS WITH SUPPLY VOLTAGE 24 VOLT AND 11+PE POLE CONNECTOR

Command signal 0 to ±10 mA floating, Valves with current command input

The spool stroke of the valve is proportional to $I_4 = -I_5$. 100% valve opening P ↗ A and B ↘ T is achieved at $I_4 = +10$ mA. At 0 mA command, the spool is in centered position. The input pins D and E are inverting. Either pin 4 or 5 is used according to the required operating direction. The other pin is connected to signal ground at cabinet side.

Command signal 0 to ±10 V, Valves with voltage command input

The spool stroke of the valve is proportional to $(U_4 - U_5)$. 100% valve opening P ↗ A and B ↘ T is achieved at $(U_4 - U_5) = +10$ V. At 0 V command the spool is in centered position. The input stage is a differential amplifier. If only one command signal is available, pin 4 or 5 is connected to signal ground at cabinet side according to the required operating direction.

Actual value 4 to 20 mA

The actual spool position value can be measured at pin 6 (see diagram on the top). This signal can be used for monitoring and fault detection purposes. The spool stroke range corresponds to 4 to 20 mA. The centered position is at 12 mA. 20 mA corresponds to 100% valve opening P ↗ A and B ↘ T.

Circuit diagram for measurement of actual value I_6 (position of main spool) for valves with 11 + PE pole connector (signal "M and X")

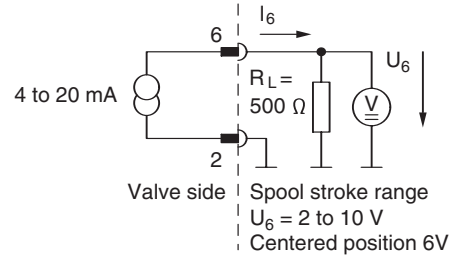

(Signal type "D" R_L integrated on electronics)

The position signal output 4 to 20 mA allows to detect a cable break when $I_6 = 0$ mA. For failure detection purposes, it is advised to connect pin 6 of the mating connector and route this signal to the control cabinet.

Note: Enable input

With enable signal off, the main spool will move to a safe position. Spool position $\pm 3\%$.

- a) Defined centered position (Unbiased pilot valve). Function code S or G
- b) End position (Biased pilot valve). Function code H¹⁾

¹⁾ see type designation

WIRING FOR VALVES WITH 6+PE POLE CONNECTOR

To EN 175201 Part 804, and mating connector (metal shell) with leading protective earth connection (\perp). Also see input command wiring schematic, Page 40 (see additional information in AM 426 E spec.).

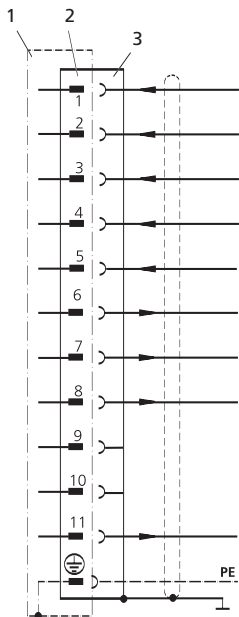

- 1 Valve
- 2 Connector
- 3 Mating connector

Function	Voltage command	Current command
1 Supply	24 V DC (min. 18 V DC, max. 32 V DC)	Static: $I_{max.}$ 200 mA Dynamic: $I_{max.}$ 800 mA
2 Supply / Signal ground	\perp (0 V)	
3 Enabled Not enabled	$U_{3-2} > +8.5$ V DC $U_{3-2} < +6.5$ V DC	$I_e = 2.0$ mA at 24 V DC, max. 32 V DC (see note above)
4 Input rated command 5 (differential)	$U_{4-5} = 0$ to ± 10 V $R_e = 10$ k Ω	Input command $I_4 = -I_5$: 0 to ± 10 mA ($R_e = 200$ Ω) Inputs U_{4-2} and U_{5-2} for both signal types limited to min. -15 V and max. +32 V
6 Output actual value spool position	$I_{6-2} = 4$ to 20 mA. At 12 mA spool is in centered position. $R_L = 100$ bis 500 Ω Signal code D: $U_{6-2} = 2$ to 10 V. At 6 V spool is in centered position. $R_L = 500$ Ω	
7 Auxiliary signal	Spool position $U_{7-2} = 13$ to 3 V. At 8 V spool is in centered position. $R_L = 5$ k Ω	
8 Valve ready	$U_{8-2} > +8.5$ V DC: Enable and supply ok $U_{8-2} < +6.5$ V DC: Not enabled or supply not ok	Output $I_{max.}$: 20 mA
9 Not used		
10 Not used		
11 Nominal - actual valve Position error, logic	$U_{11-2} > +8.5$ V DC: $< +30\%$ deviation $U_{11-2} < +6.5$ V DC: $> +30\%$ deviation	Output $I_{max.}$: 20 mA
\perp Protective earth		

Additional information on command signal on page 40.

Model ... Type			D681 - P.H.UO/W	D681 - P.H.UF
Mounting pattern	ISO, with additional 2 nd T port		ISO 4401-05-05-0-94	
Valve version			4-way, 2x2-way, 5-way 2-stage, standard spool	
			O/W (spring centered)	F (Spring A♦T)
Pilot valve	O _N at Δp _N = 70 bar (1021 psi)	l/min (gpm)	3.5 (0.92)	3.7 (0.98)
Series	D633-7... (80 N) [355 lbs]		Standard	biased
Pilot connection			X and Y	X and Y
Mass		kg (lb)	O = 6.8 (15) / W = 8.0 (17.6)	6.8 (15)
Rated flow	(± 10%) at Δp _N = 5 bar per land	l/min (gpm)	30 / 60 / 80 (7.9 / 15.9 / 21.1)	
Operating pressure max.	Ports P, A, B, T and X with Y external	bar (psi)	350 (5080)	
	Port T with Y external	bar (psi)	250 (3570)	
	Ports T with Y internal and Y external (pressure peaks 210 bar (3050 psi))	bar (psi)	70 (1020)	
Response time*		ms	11	
Threshold*		%	< 0.03	
Hysteresis*		%	< 0.2	
Null shift*	with ΔT = 55 K	%	< 1.5	
Null leakage flow*	total max. (~ critical lap)	l/min (gpm)	2.2 (0.57)	
Null leakage flow*	pilot stage only, max.	l/min (gpm)	0.4 (0.10)	
Pilot flow*	max., for 100% step input	l/min (gpm)	6.0 (1.58)	
Main spool stroke		mm (in)	± 3.0 (0.12)	
Spool drive area		cm ² (in ²)	2.0 (0.31)	

* At 210 bar (3050 psi) pilot or operating pressure, fluid viscosity of 32 mm²/s (1.26 in²/s) and fluid temperature of 40 °C (104 °F).

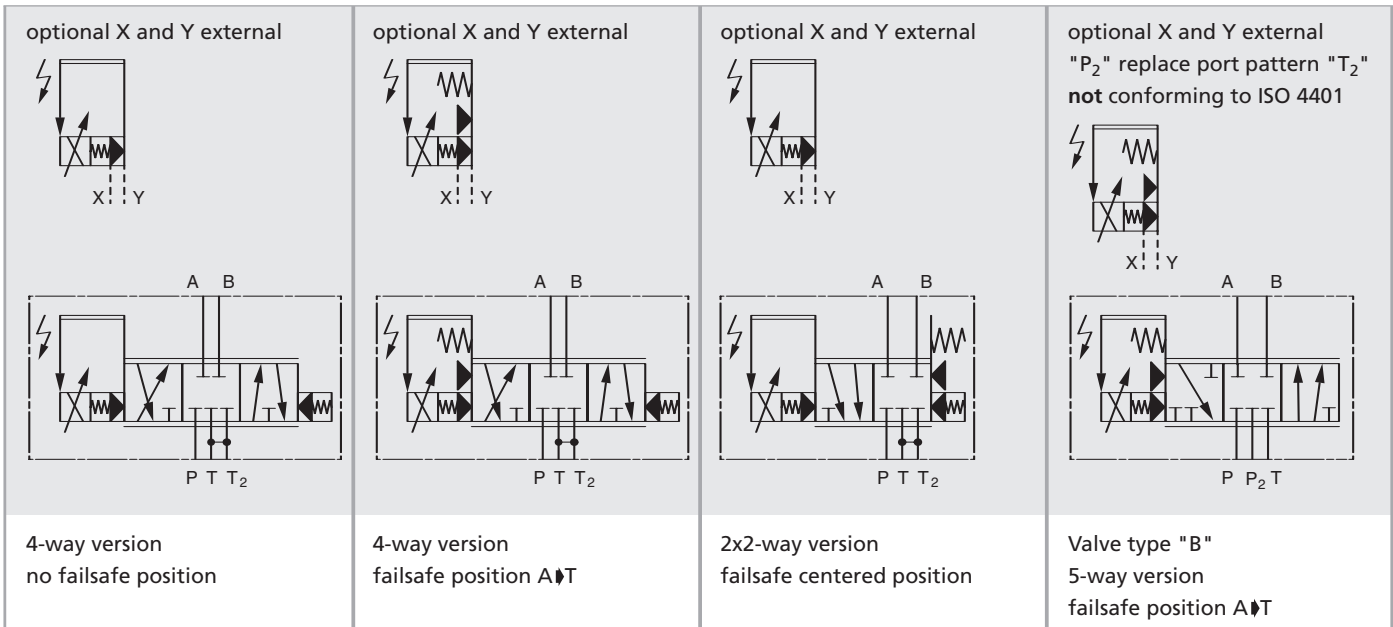

Typical characteristic curves at 210 bar pilot or operating pressure, fluid viscosity of 32 mm²/s and fluid temperature of 40°C

Flow vs. signal curves
at $\Delta p_N = 5 \text{ bar (75 psi)}$ per land

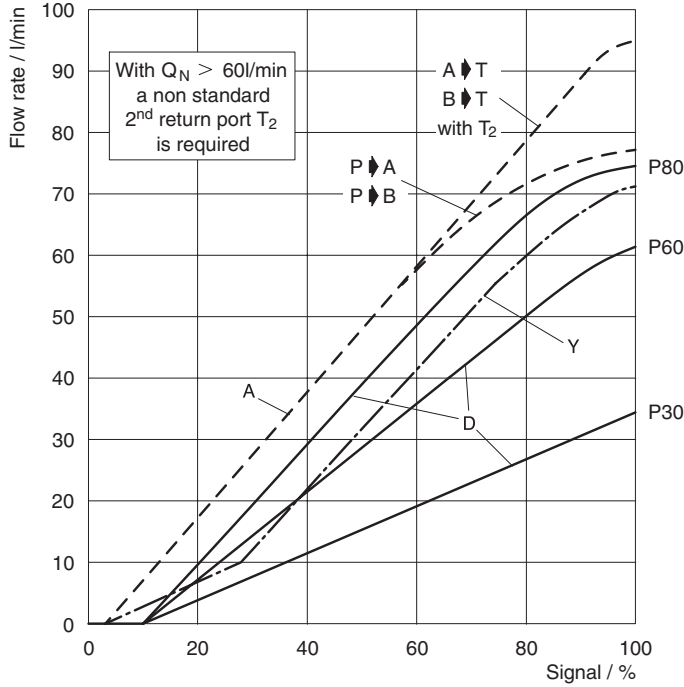

- 10 l/min = 2.6 gpm
- 20 l/min = 5.3 gpm
- 30 l/min = 7.9 gpm
- 40 l/min = 10.6 gpm
- 50 l/min = 13.2 gpm
- 60 l/min = 15.9 gpm
- 70 l/min = 18.5 gpm
- 80 l/min = 21.1 gpm
- 90 l/min = 23.8 gpm
- 100 l/min = 26.4 gpm

210 bar = 3050 psi
40°C = 104°F

Spool version A: ~critical lap, linear characteristic (80)
Spool version D: 10 % overlap, linear characteristic
Spool version Y: ~critical lap, curvilinear characteristic (80)

Step response
D681 - P.H.UO/W

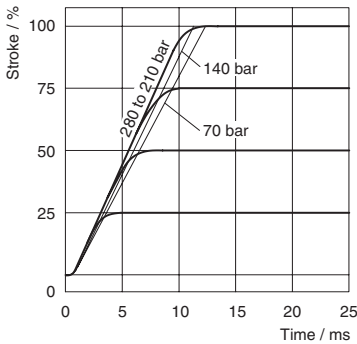

70 bar = 1020 psi
140 bar = 2030 psi
210 bar = 3050 psi
280 bar = 4060 psi

Step response
D681 - P.H.UF

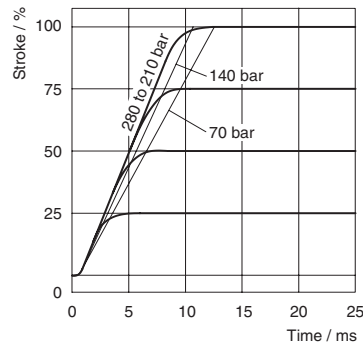

70 bar = 1020 psi
140 bar = 2030 psi
210 bar = 3050 psi
280 bar = 4060 psi

Frequency response
D681 - P.H.UO/W

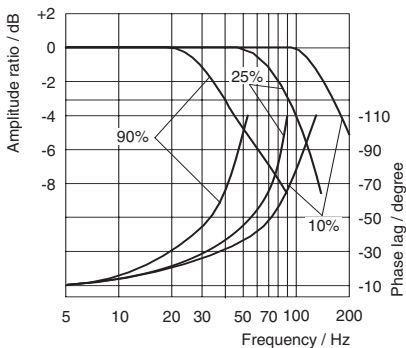

Frequency response
D681 - P.H.UF

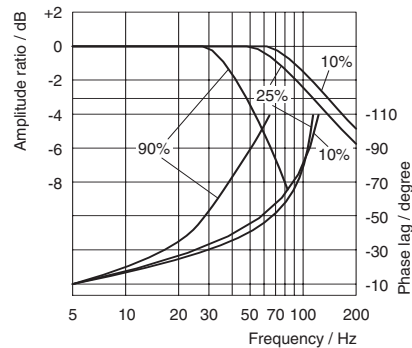

INSTALLATION DRAWING (mm)

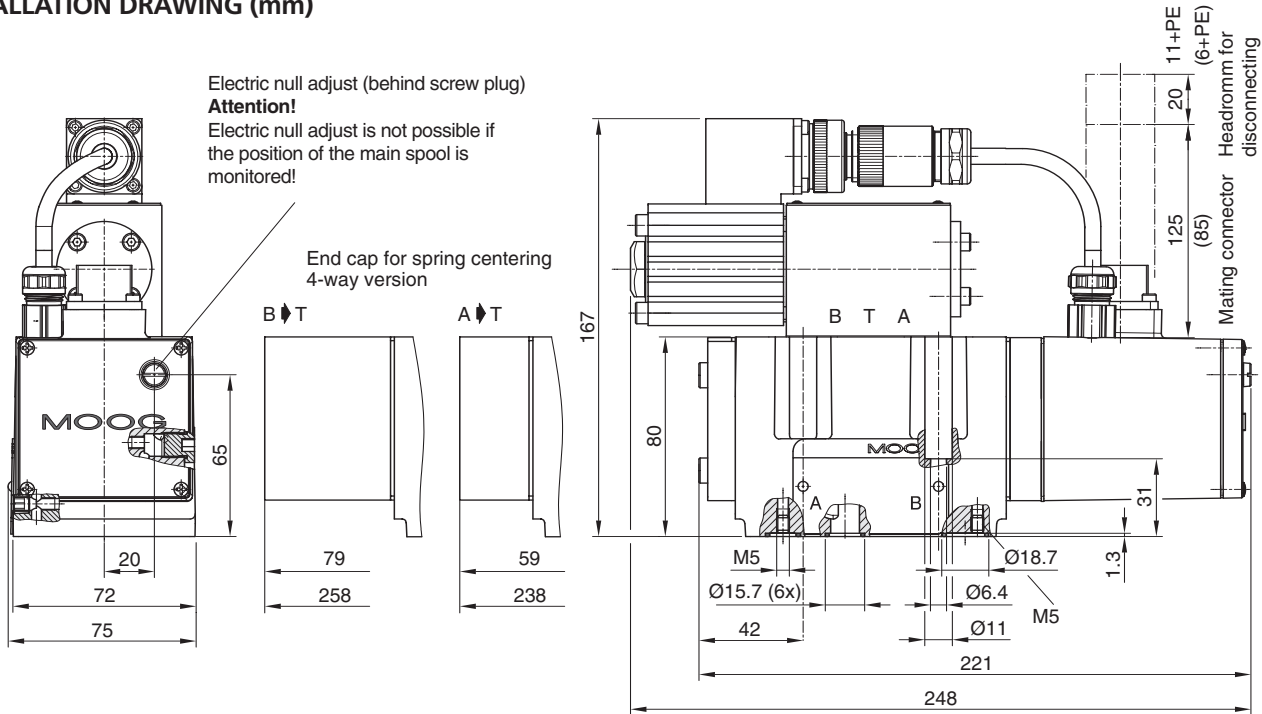

The mounting manifold must conform to ISO 4401-05-05-0-94.

Attention: Notice O-ring recess dia of X and Y ports.

For valves in 4-way version with $Q_N > 60$ l/min and in 2x2-way version, the non standard 2nd return port T_2 must be used.

With 5-way version type B80..., replace T_2 to P_2 . For maximum flow, the manifold ports P, T, A and B are required to have 11.5 mm dia (deviation from standard).

Mounting surface needs to be flat within 0.01 mm over a distance of 100 mm. Average surface finish value, R_a , better than 0.8 μ m.

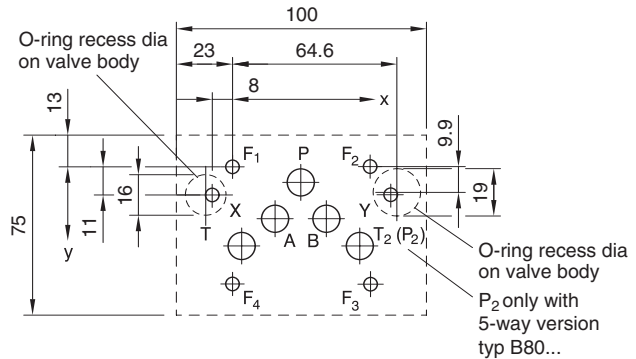

mm

	P	A	B	T	T ₂	X	Y	F ₁	F ₂	F ₃	F ₄
	Ø11.5	Ø11.5	Ø11.5	Ø11.5	Ø11.5	Ø6.3	Ø6.3	M6	M6	M6	M6
x	27	16.7	37.3	3.2	50.8	-8	62	0	54	54	0
y	6.3	21.4	21.4	32.5	32.5	11	11	0	0	46	46

Spare Parts and Accessories

O-rings (included in delivery)		NBR 85 Shore	FPM 85 Shore
for P, T, T ₂ , A, B, X	6 pieces ID 12.4 x Ø 1.8	-45122-004	-42082-004
for Y	1 piece ID 15.6 x Ø 1.8	-45122-011	-42082-011
Mating connector, waterproof IP65 (not included in delivery)		for cable dia	
6+PE-pole	B97007-061	EN 175201 Part 804	min. Ø 10 mm, max. Ø 12 mm
11+PE-pole	B97067-111	EN 175201 Part 804	min. Ø 11 mm, max. Ø 13 mm
Flushing plates	for P, A, B, T, T ₂ , X, Y	for P, T, T ₂ , X, Y	for P, T, T ₂ , and X, Y
	B67728-001	B67728-002	B67728-003
Mounting manifolds	see special data sheet		
Mounting bolts (not included in delivery)		required torque	required
M 6 x 40 DIN EN ISO 4762 -10.9	A03665-060-040	11 Nm	4 pieces
Service Seal Kit	B97215	N681-10	V681-10

INSTALLATION DRAWING (inch)

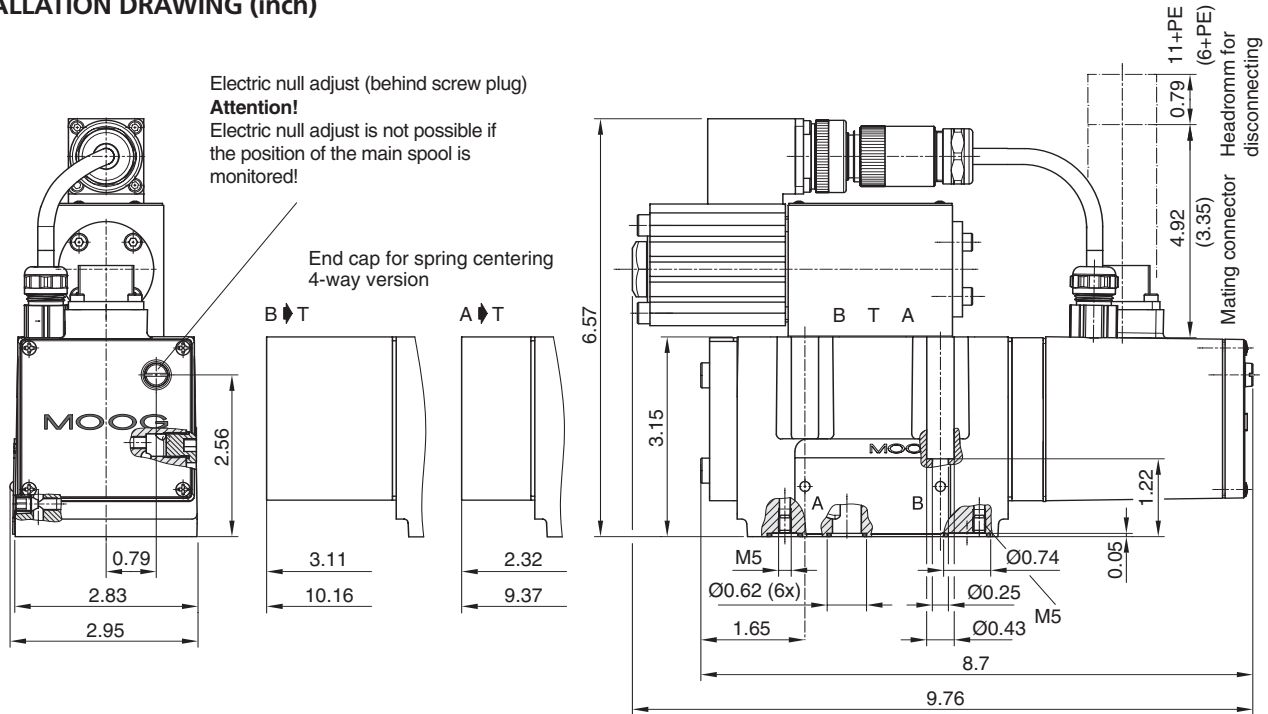

The mounting manifold must conform to ISO 4401-05-05-0-94.

Attention: Notice O-ring recess dia of X and Y ports. For valves in 4-way version with $Q_N > 15.9$ gpm and in 2x2-way version, the non standard 2nd return port T₂ must be used. With 5-way version type B80..., replace T₂ to P₂. For maximum flow, the manifold ports P, T, A and B are required to have 0.45 inch dia (deviation from standard). Mounting surface needs to be flat within 0.0004 inch over a distance of 3.94 inch. Average surface finish value, Ra, better than 32 micro inch.

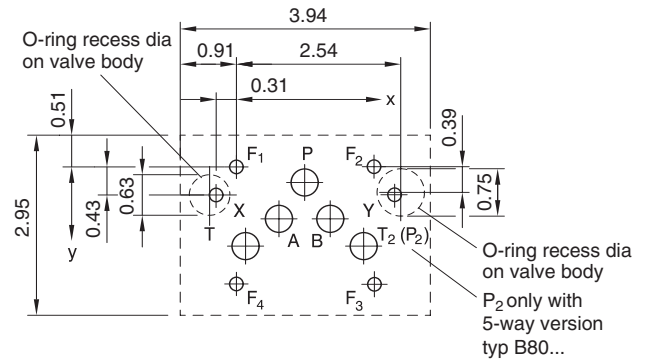

inch

	P	A	B	T	T ₂	X	Y	F ₁	F ₂	F ₃	F ₄
	Ø0.45	Ø0.45	Ø0.45	Ø0.45	Ø0.45	Ø0.25	Ø0.25	M6	M6	M6	M6
x	1.06	0.66	1.47	0.13	2.0	-0.31	2.44	0	2.13	2.13	0
y	0.25	0.84	0.84	1.28	1.28	0.43	0.43	0	0	1.81	1.81

Spare Parts and Accessories

O-rings (included in delivery)											NBR 85 Shore	FPM 85 Shore
for P, T, T ₂ , A, B, X						6 pieces ID 0.492 x Ø 0.07					-45122-004	-42082-004
for Y						1 piece ID 0.614 x Ø 0.07					-45122-011	-42082-011
Mating connector, waterproof IP65 (not included in delivery)											for cable dia	
6+PE-pole						B97007-061			EN 175201 Part 804		min. Ø 0.39 in, max. Ø 0.47 in	
11+PE-pole						B97067-111			EN 175201 Part 804		min. Ø 0.43 in, max. Ø 0.51 in	
Flushing plates						for P, A, B, T, T ₂ , X, Y			for P, T, T ₂ , X, Y		for P, T, T ₂ , and X, Y	
						B67728-001			B67728-002		B67728-003	
Mounting manifolds						see special data sheet						
Mounting bolts (not included in delivery)									required torque		required	
M 6 x 1.6 DIN EN ISO 4762 -10.9						A03665-060-040			8 ft/lbs		4 pieces	
Service Seal Kit						B97215					N681-10	V681-10

Model ... Type			D682 - P.H.UO/W	D682 - P.H.UF/D
Mounting pattern			ISO 4401-07-06-0-94	
Valve version			4-way, 2x2-way 2-stage, standard spool	
			O/W (spring centered)	F/D (Spring A / B↗T)
Pilot valve	Q_N at $\Delta p_N = 70$ bar (1020 psi)	l/min (gpm)	20 (5.3)	15 (4.0)
Series	D633-7... (80 N) [355 lbs]		Standard	biased
Pilot connection			X and Y	X and Y
Mass		kg (lb)	O = 12 (26.5) / W = 13.4 (29.5)	12 (26.5)
Rated flow	($\pm 10\%$) at $\Delta p_N = 5$ bar per land	l/min (gpm)	150 / 250 (39.6 / 66.0)	
Operating pressure max.	Ports P, A, B, T and X with Y external	bar (psi)	350 (5080)	
	Ports T with Y internal and Y external (pressure peaks 210 bar (3050 psi))	bar	70 (1020)	70 (1020)
Response time*		ms	11	13
Threshold*		%	< 0.02	< 0.02
Hysteresis*		%	< 0.2	< 0.2
Null shift*	with $\Delta T = 55$ K	%	< 1.2	< 1.0
Null leakage flow*	total max. (~ critical lap)	l/min (gpm)	3.0 (0.79)	3.0 (0.79)
Null leakage flow*	pilot stage only, max.	l/min (gpm)	0.5 (0.13)	0.5 (0.13)
Pilot flow*	max., for 100% step input	l/min (gpm)	25 (6.6)	20 (5.3)
Main spool stroke		mm (in)	± 5.0 (0.19)	
Spool drive area		cm ² (in ²)	5.0 (0.78)	

* At 210 bar (3050 psi) pilot or operating pressure, fluid viscosity of 32 mm²/s (1.26 in²/s) and fluid temperature of 40 °C (104 °F)

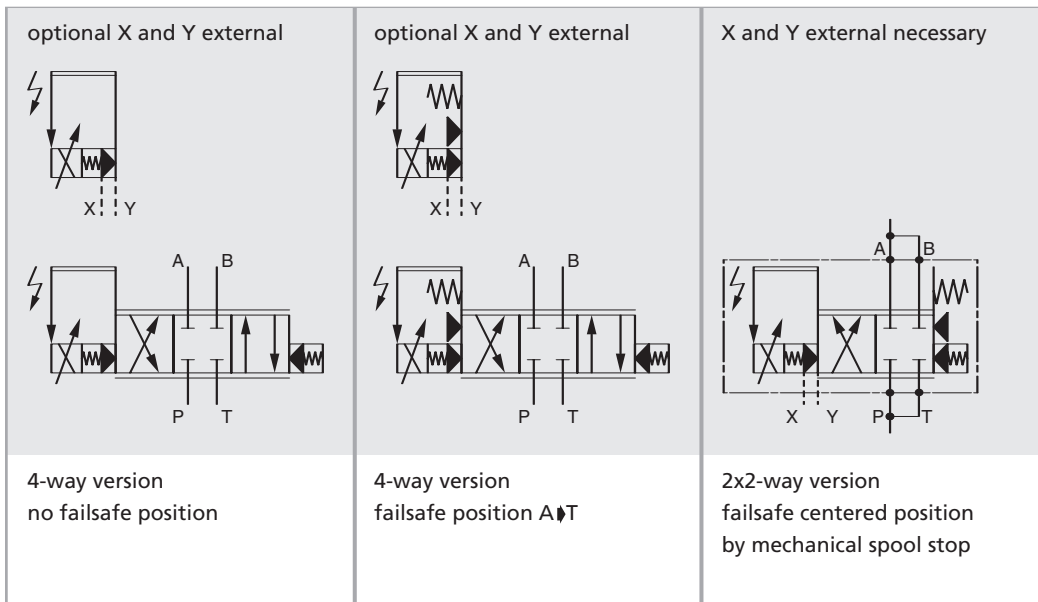

Typical characteristic curves at 210 bar pilot or operating pressure, fluid viscosity of 32 mm²/s and fluid temperature of 40°C

Flow vs. signal curves

at $\Delta p_N = 5 \text{ bar (75 psi)}$ per land

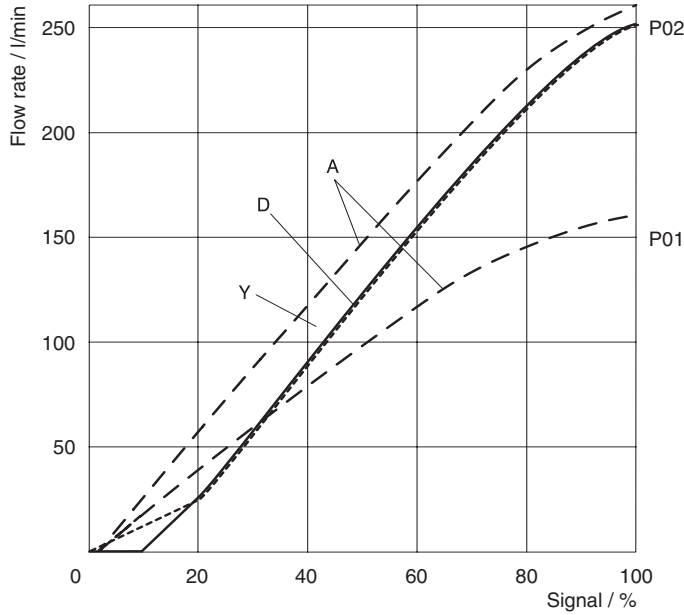

100 l/min = 26.4 gpm	210 bar = 3050 psi
200 l/min = 52.8 gpm	40°C = 104°F
300 l/min = 79.3 gpm	
350 l/min = 92.5 gpm	
400 l/min = 106.0 gpm	

Spool version A: ~critical lap, linear characteristic (80)
 Spool version D: 10% overlap, linear characteristic
 Spool version Y: ~critical lap, curvilinear characteristic (80)

Step response D682 - P..H.UO/W

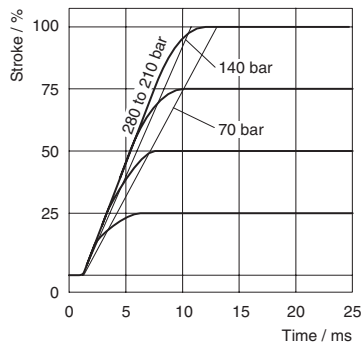

70 bar = 1020 psi
140 bar = 2030 psi
210 bar = 3050 psi
280 bar = 4060 psi

Step response D682 - P..H.UF/D

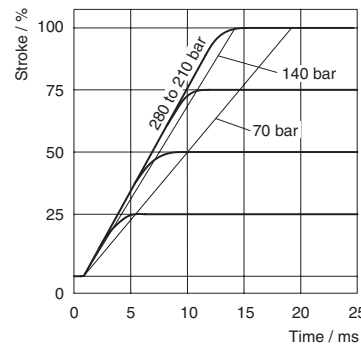

70 bar = 1020 psi
140 bar = 2030 psi
210 bar = 3050 psi
280 bar = 4060 psi

Frequency response D682 - P..H.UO/W

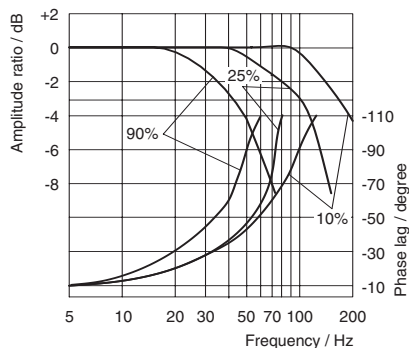

Frequency response D682 - P..H.UF/D

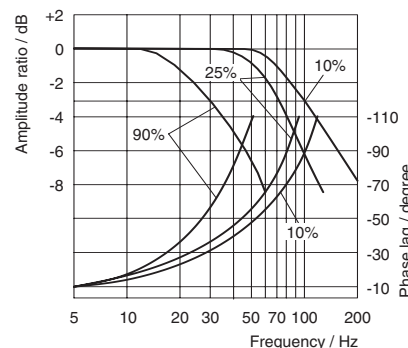

INSTALLATION DRAWING (mm)

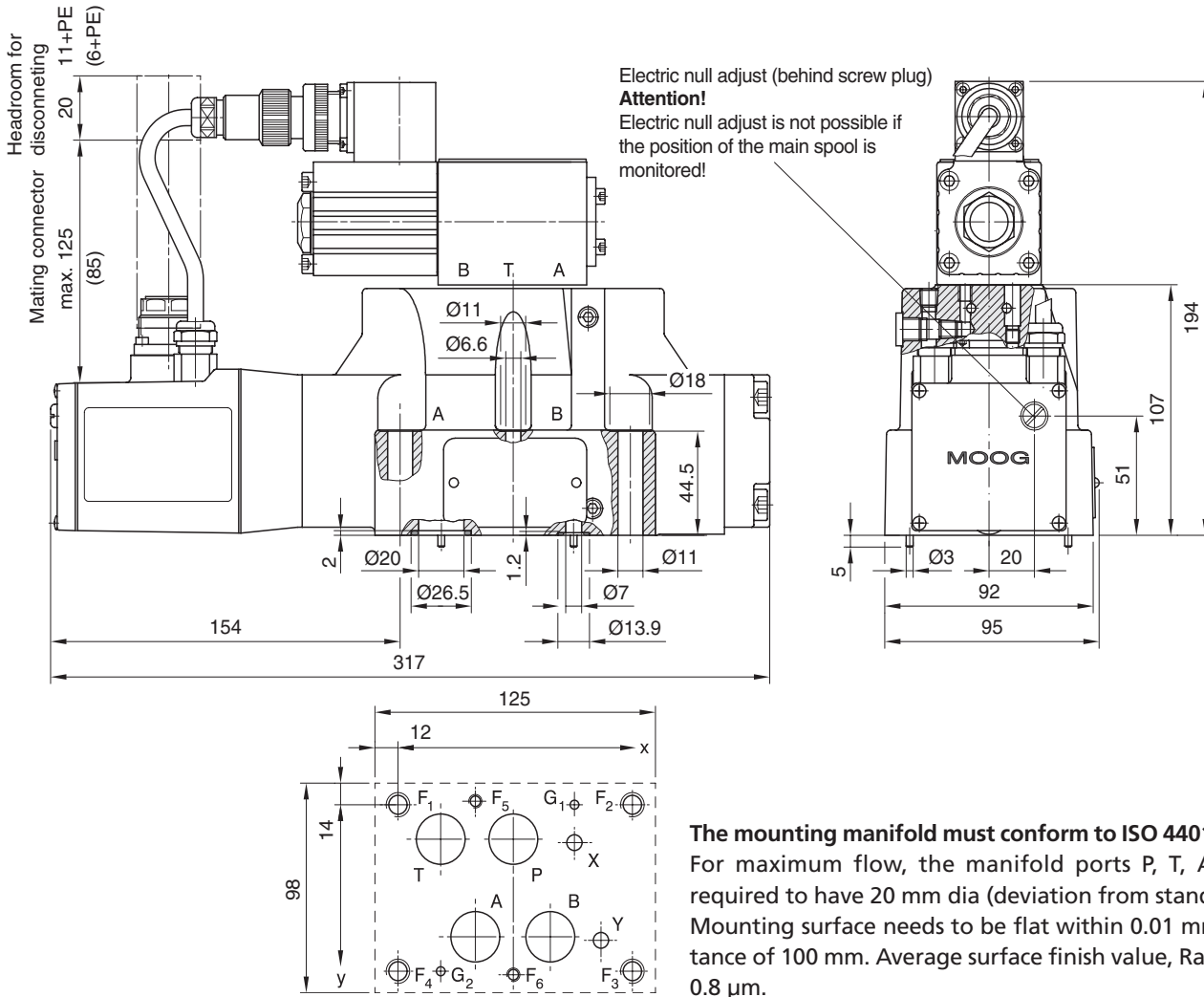

The mounting manifold must conform to ISO 4401-07-06-0-94. For maximum flow, the manifold ports P, T, A and B are required to have 20 mm dia (deviation from standard). Mounting surface needs to be flat within 0.01 mm over a distance of 100 mm. Average surface finish value, Ra, better than 0.8 µm.

mm

	P	A	T	B	X	Y	G ₁	G ₂	F ₁	F ₂	F ₃	F ₄	F ₅	F ₆
	Ø20	Ø20	Ø20	Ø20	Ø6.3	Ø6.3	Ø4	Ø4	M10	M10	M10	M10	M6	M6
x	50	34.1	18.3	65.9	76.6	88.1	76.6	18.3	0	101.6	101.6	0	34.1	50
y	14.3	55.6	14.3	55.6	15.9	57.2	0	69.9	0	0	69.9	69.9	-1.6	71.5

Spare Parts and Accessories

O-rings (included in delivery)		NBR 85 Shore	FPM 85 Shore
for P, T, A, B	4 pieces ID 21.89 x Ø 2.6	-45122-129	-42082-129
for X, Y	2 pieces ID 10.82 x Ø 1.8	-45122-022	-42082-022
Mating connector, waterproof IP65 (not included in delivery)		for cable dia	
6+PE-pole	B97007-061	EN175201 Part 804	min. Ø 10 mm, max. Ø 12 mm
11+PE-pole	B97067-111	EN175201 Part 804	min. Ø 11 mm, max. Ø 13 mm
Flushing plate	-76741		
Mounting manifolds	B46891-001		
Mounting bolts (not included in delivery)		required torque	required
M 10 x 60 DIN EN ISO 4762 -10.9	A03665-100-060	54 Nm	4 pieces
M 6 x 55 DIN EN ISO 4762 -10.9	A03665-060-055	11 Nm	2 pieces
Service Seal Kit	B97215-	N6x2-16	V6x2-16

INSTALLATION DRAWING (inch)

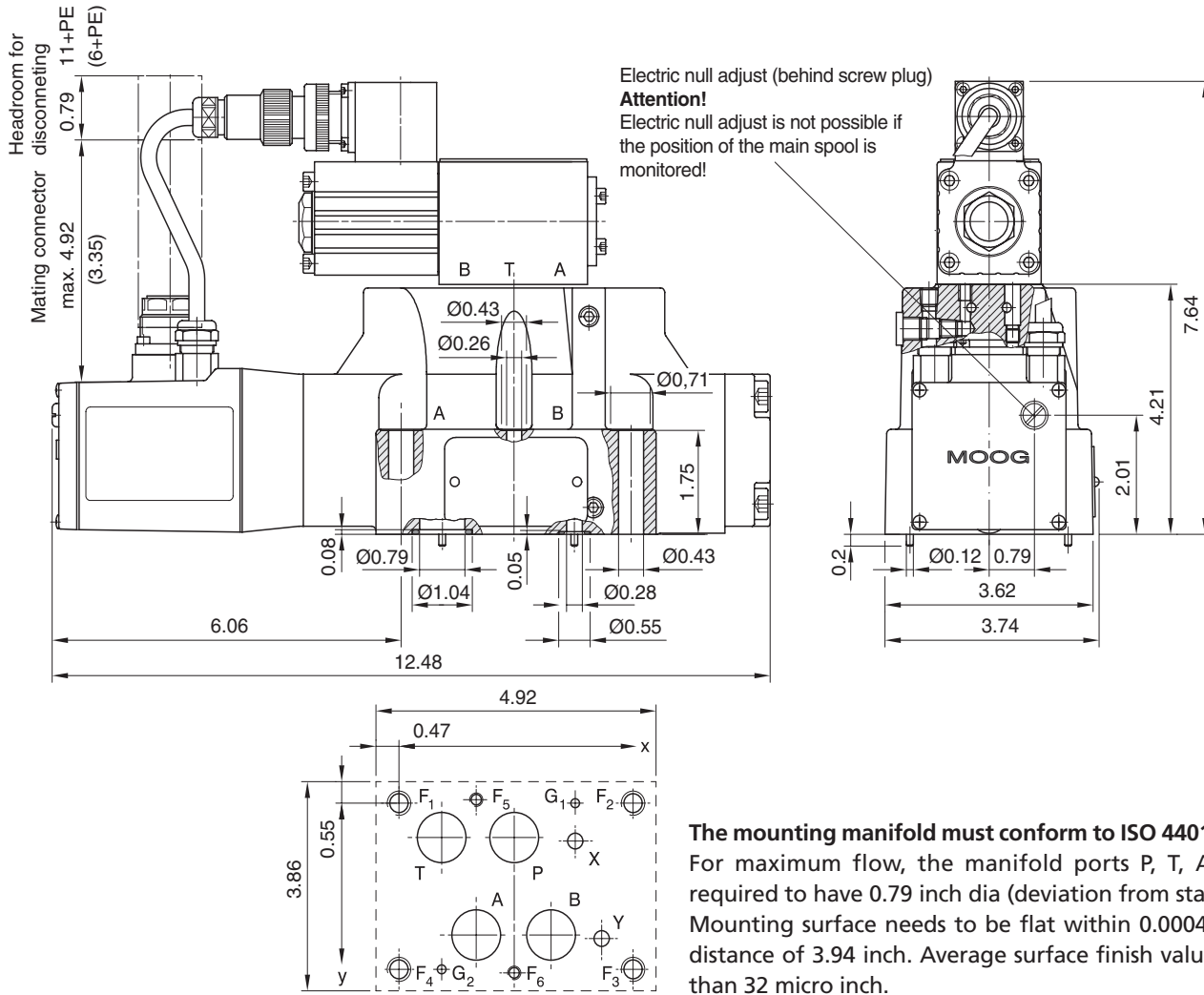

The mounting manifold must conform to ISO 4401-07-06-0-94. For maximum flow, the manifold ports P, T, A and B are required to have 0.79 inch dia (deviation from standard). Mounting surface needs to be flat within 0.0004 inch over a distance of 3.94 inch. Average surface finish value, Ra, better than 32 micro inch.

inch

	P	A	T	B	X	Y	G ₁	G ₂	F ₁	F ₂	F ₃	F ₄	F ₅	F ₆
	Ø0.79	Ø0.79	Ø0.79	Ø0.79	Ø0.25	Ø0.25	Ø0.16	Ø0.16	M10	M10	M10	M10	M6	M6
x	1.97	1.34	0.72	2.59	3.02	3.47	3.02	0.72	0	4.0	4.0	0	1.34	1.97
y	0.56	2.19	0.56	2.19	0.63	2.25	0	2.75	0	0	2.75	2.75	-0.06	2.81

Spare Parts and Accessories

O-rings (included in delivery)		NBR 85 Shore	FPM 85 Shore
for P, T, A, B	4 pieces ID 0.86 x Ø 0.1	-45122-129	-42082-129
for X, Y	2 pieces ID 0.43 x Ø 0.07	-45122-022	-42082-022
Mating connector, waterproof IP65 (not included in delivery)		for cable dia	
6+PE-pole	B97007-061	EN175201 Part 804	min. Ø 0.39 in, max. Ø 0.47 in
11+PE-pole	B97067-111	EN175201 Part 804	min. Ø 0.43 in, max. Ø 0.51 in
Flushing plate	-76741		
Mounting manifolds	B46891-001		
Mounting bolts (not included in delivery)		required torque	required
M 10 x 2.4 DIN EN ISO 4762 -10.9	A03665-100-060	40 ft/lbs	4 pieces
M 6 x 2.2 DIN EN ISO 4762 -10.9	A03665-060-055	8 ft/lbs	2 pieces
Service Seal Kit	B97215-	N6X2-16	V6X2-16

Model ... Type			D683 - N..H.UO/W	D683 - N..H.UF/D
Mounting pattern			ISO 4401-08-07-0-94	
Valve version			4-way, 2x2-way 2-stage, stub shaft spool ¹⁾	
			O/W (spring centered)	F/D (spring A / B↗T)
Pilot valve	$Q_N (\pm 10\%)$ at $\Delta p_N = 70$ bar (1020 psi)	l/min (gpm)	20 (5.3)	15 (4.0)
Series	D633-7... (80 N) [355 lbs]		Standard	biased
Pilot connection			X and Y	X und Y
Mass		kg (lb)	O = 20 (44.1) / W = 21.5 (47.4)	20 (44.1)
Rated flow	($\pm 10\%$) at $\Delta p_N = 5$ bar per land	l/min (gpm)	350 (92.5)	350 (92.5)
Operating pressure max.	Ports P, A, B, T and X with Y external	bar (psi)	350 (5080)	350 (5080)
	Ports T with Y internal and Y external (pressure peaks 210 bar (3050 psi))	bar (psi)	70 (1020)	70 (1020)
Response time*		ms	10	13
Threshold*		%	< 0.02	< 0.02
Hysteresis*		%	< 0.2	< 0.2
Null shift*	with $\Delta T = 55$ K	%	< 1.2	< 1.0
Null leakage flow*	total max. (~ critical lap)	l/min (gpm)	3.5 (0.92)	3.5 (0.92)
Null leakage flow*	pilot stage only, max.	l/min (gpm)	0.5 (0.13)	0.5 (0.13)
Pilot flow*	max., for 100% step input	l/min (gpm)	20 (5.3)	16 (4.2)
Main spool stroke		mm (in)	± 4.5 (0.18)	± 4.5 (0.18)
Spool drive area		cm ² (in ²)	4.9 (0.75)	4.9 (0.75)

*) At 210 bar (3050 psi) pilot or operating pressure, fluid viscosity of 32 mm²/s (1.26 in²/s) and fluid temperature of 40 °C (104 °F)

¹⁾ Option: D683-P03 with standard spool

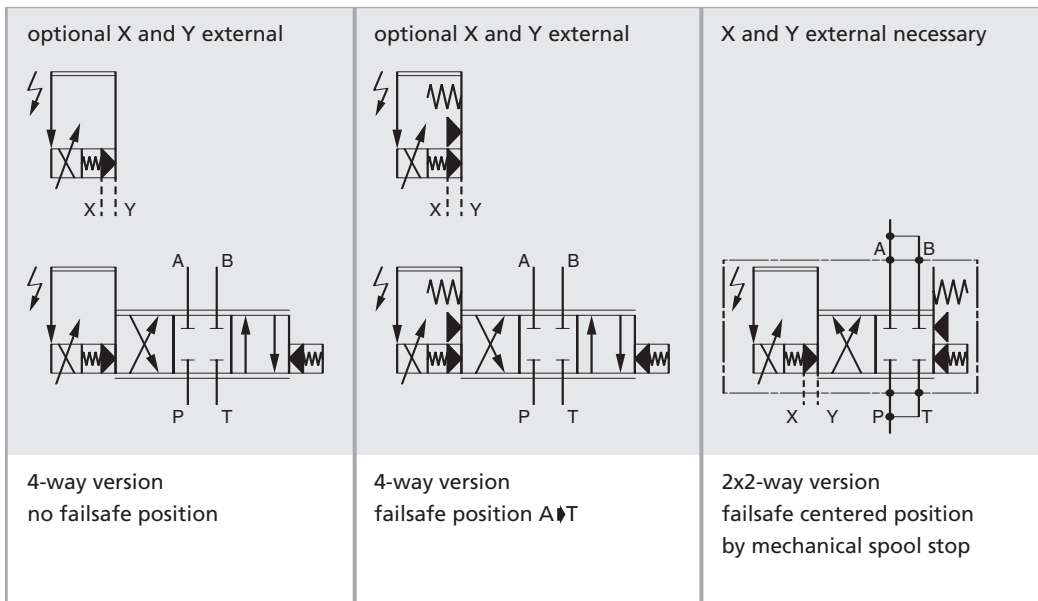

Typical characteristic curves at 210 bar pilot or operating pressure, fluid viscosity of 32 mm²/s and fluid temperature of 40 °C

Flow vs. signal curves

at $\Delta p_N = 5$ bar (75 psi) per land

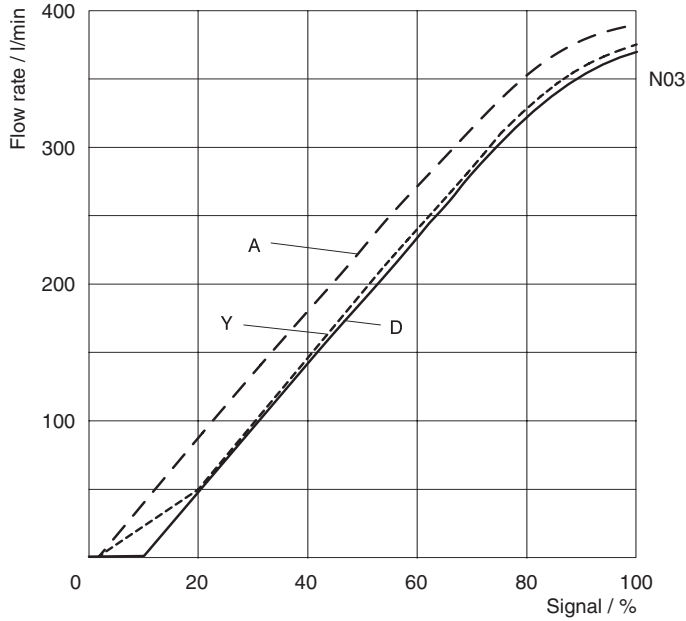

100 l/min = 26.4 gpm
 200 l/min = 52.8 gpm
 300 l/min = 79.3 gpm
 350 l/min = 92.5 gpm
 400 l/min = 106.0 gpm

210 bar = 3050 psi
 40°C = 104°F

Spool version A: ~critical lap, linear characteristic
 Spool version D: 10 % overlap, linear characteristic
 Spool version Y: ~critical lap, curvilinear characteristic

Step response

D683 - N..H.UO/W

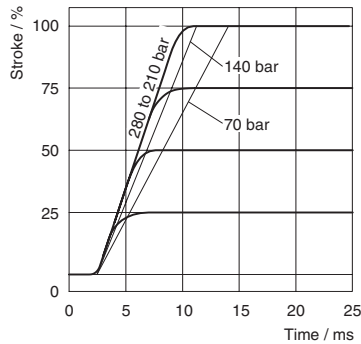

70 bar = 1020 psi
 140 bar = 2030 psi
 210 bar = 3050 psi
 280 bar = 4060 psi

Step response

D683 - N..H.UF/D

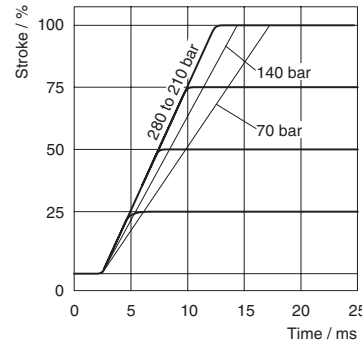

70 bar = 1020 psi
 140 bar = 2030 psi
 210 bar = 3050 psi
 280 bar = 4060 psi

Frequency response

D683 - N..H.UO/W

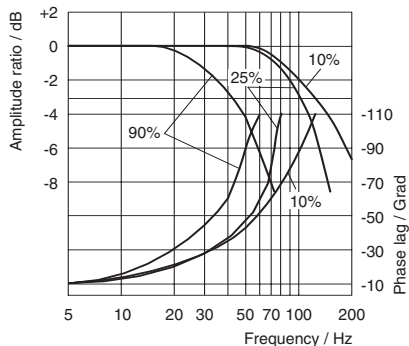

Frequency response

D683 - N..H.UF/D

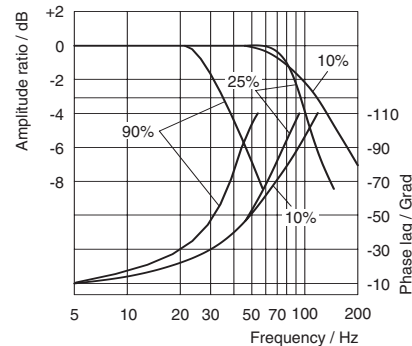

INSTALLATION DRAWING (mm)

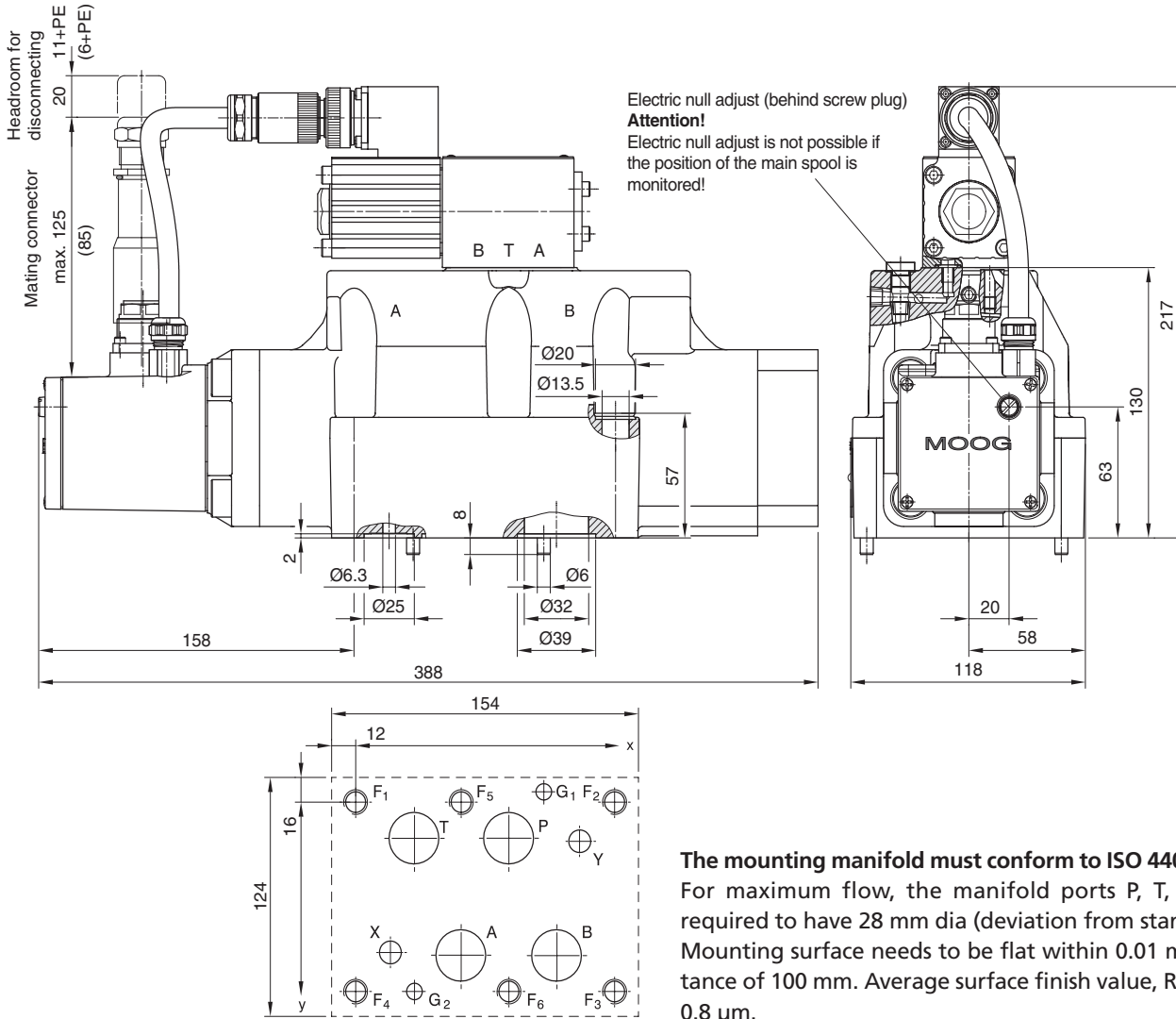

The mounting manifold must conform to ISO 4401-08-07-0-94. For maximum flow, the manifold ports P, T, A and B are required to have 28 mm dia (deviation from standard). Mounting surface needs to be flat within 0.01 mm over a distance of 100 mm. Average surface finish value, Ra, better than 0.8 µm.

mm

	P	A	T	B	X	Y	G ₁	G ₂	F ₁	F ₂	F ₃	F ₄	F ₅	F ₆
	Ø28	Ø28	Ø28	Ø28	Ø11.2	Ø11.2	Ø7.5	Ø7.5	M12	M12	M12	M12	M12	M12
x	77	53.2	29.4	100.8	17.5	112.7	94.5	29.4	0	130.2	130.2	0	53.2	77
y	17.5	74.6	17.5	74.6	73	19	-4.8	92.1	0	0	92.1	92.1	0	92.1

Spare Parts and Accessories

O-rings (included in delivery)		NBR 85 Shore	FPM 85 Shore
for P, T, A, B:	4 pieces ID 34.60 x Ø 2.6	-45122-113	-42082-113
for X, Y:	2 pieces ID 20.29 x Ø 2.6	-45122-195	-42082-195
Mating connector, waterproof IP65 (not included in delivery)		for cable dia	
6+PE-pole	B97007-061	EN175201 Part 804	min. Ø 10 mm, max. Ø 12 mm
11+PE-pole	B97067-111	EN175201 Part 804	min. Ø 11 mm, max. Ø 13 mm
Flushing plate	-76047-001		
Mounting manifolds	A25855-009		
Mounting bolts (not included in delivery)		required torque	required
M 12 x 75 DIN EN ISO 4762 -10.9	A03665-120-075	94 Nm	6 pieces
Service Seal Kit	B97215		N6X4-25 V6X4-25

INSTALLATION DRAWING (inch)

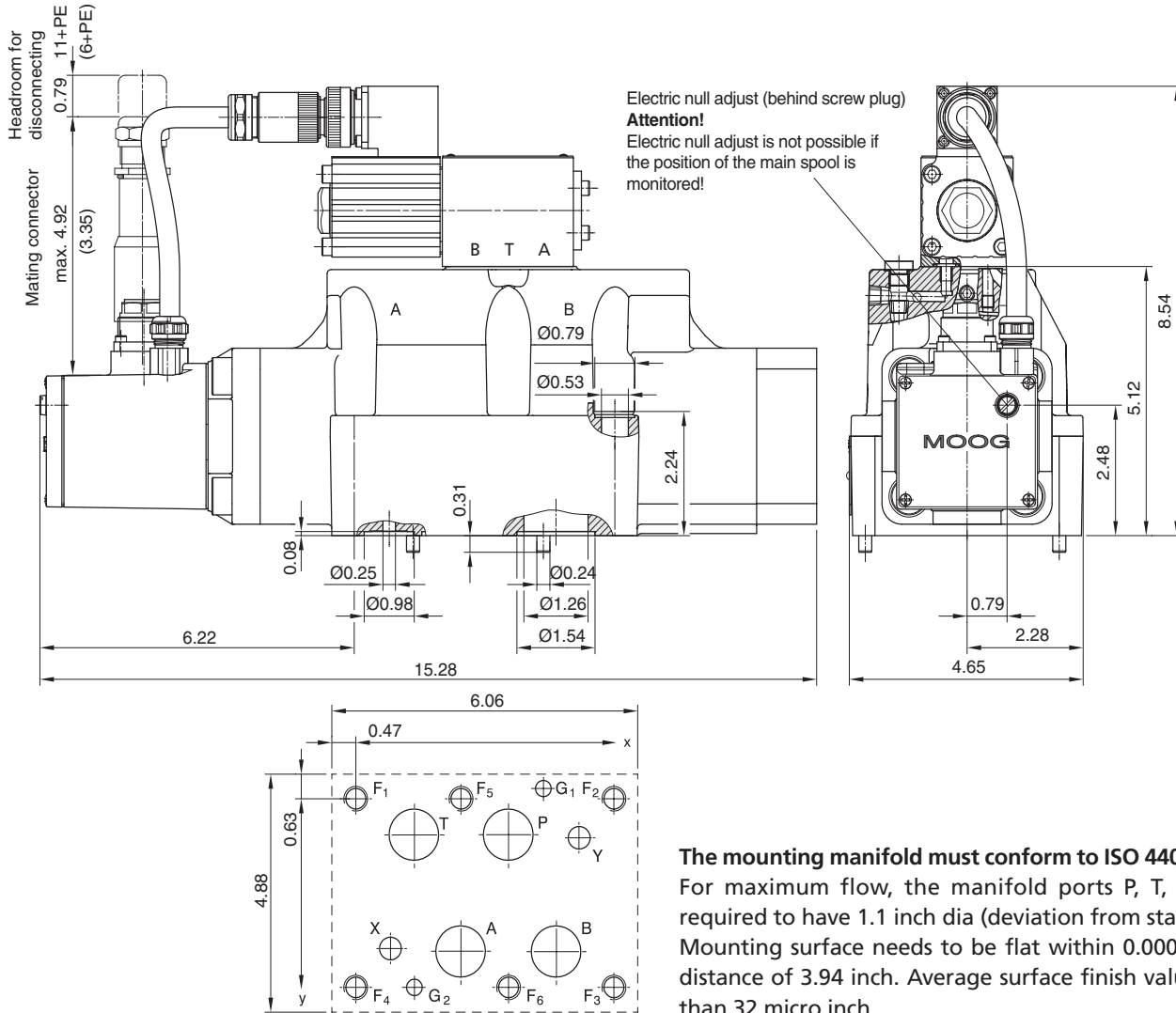

The mounting manifold must conform to ISO 4401-08-07-0-94. For maximum flow, the manifold ports P, T, A and B are required to have 1.1 inch dia (deviation from standard). Mounting surface needs to be flat within 0.0004 inch over a distance of 3.94 inch. Average surface finish value, Ra, better than 32 micro inch.

inch

	P	A	T	B	X	Y	G ₁	G ₂	F ₁	F ₂	F ₃	F ₄	F ₅	F ₆
	Ø1.1	Ø1.1	Ø1.1	Ø1.1	Ø0.44	Ø0.44	Ø0.3	Ø0.3	M12	M12	M12	M12	M12	M12
x	3.03	2.09	1.16	3.97	0.69	4.44	3.72	1.16	0	5.13	5.13	0	2.09	3.03
y	0.69	2.94	0.69	2.94	2.87	0.75	-0.19	3.63	0	0	3.63	3.63	0	3.63

Spare Parts and Accessories

O-rings (included in delivery)		NBR 85 Shore	FPM 85 Shore
for P, T, A, B:	4 pieces ID 1.36 x Ø 0.1	-45122-113	-42082-113
for X, Y:	2 pieces ID 0.8 x Ø 0.1	-45122-195	-42082-195
Mating connector, waterproof IP65 (not included in delivery)		for cable dia	
6+PE-pole	B97007-061	EN175201 Part 804	min. Ø 0.39 in, max. Ø 0.47 in
11+PE-pole	B97067-111	EN175201 Part 804	min. Ø 0.43 in, max. Ø 0.51 in
Flushing plate	-76047-001		
Mounting manifolds	A25855-009		
Mounting bolts (not included in delivery)		required torque	required
M 12 x 3.0 DIN EN ISO 4762 -10.9	A03665-120-075	69.56 ft/lbs	6 pieces
Service Seal Kit	B97215		N6X4-25 V6X4-25

Model ... Type			D684 - N..H.UO/W	D684 - N..H.UF/D
Mounting pattern			ISO 4401-08-07-0-94	
Valve version			4-way, 2x2-way 2-stage, stub shaft spool ¹⁾	
			O/W (spring centered)	F/D (spring A / B \blacktriangleright T)
Pilot valve	Q_N at $\Delta p_N = 70$ bar (1020 psi)	l/min (gpm)	20 (5.3)	15 (4.0)
Series	D633-7... (80 N) [355 lbs]		Standard	biased
Pilot connection			X and Y	X und Y
Mass		kg (lb)	O = 20 (44.1) / W = 21.5 (47.4)	20 (44.1)
Rated flow	($\pm 10\%$) at $\Delta p_N = 5$ bar per land	l/min (gpm)	550 (145)	550 (145)
Operating pressure max.	Ports P, A, B, T and X with Y external	bar (psi)	350 (5080)	350 (5080)
	Ports T with Y internal and Y external (pressure peaks 210 bar (3050 psi))	bar (psi)	70 (1020)	70 (1020)
Response time*		ms	12	16
Threshold*		%	< 0.02	< 0.02
Hysteresis*		%	< 0.2	< 0.2
Null shift*	at $\Delta T = 55$ K	%	< 1.2	< 1.0
Null leakage flow*	total max. (~ critical lap)	l/min (gpm)	3.5 (0.92)	3.5 (0.92)
Null leakage flow*	pilot stage only, max.	l/min (gpm)	0.5 (0.13)	0.5 (0.13)
Pilot flow*	max., for 100% step input	l/min (gpm)	20 (5.3)	16 (4.2)
Main spool stroke		mm (in)	± 6.0 (0.24)	± 6.0 (0.24)
Spool drive area		cm ² (in ²)	4.9 (0.75)	4.9 (0.75)

* At 210 bar (3050 psi) pilot or operating pressure, fluid viscosity of 32 mm²/s (1.26 in²/s) and fluid temperature of 40 °C (104 °F)

¹⁾ Option: D684-P05 with standard spool

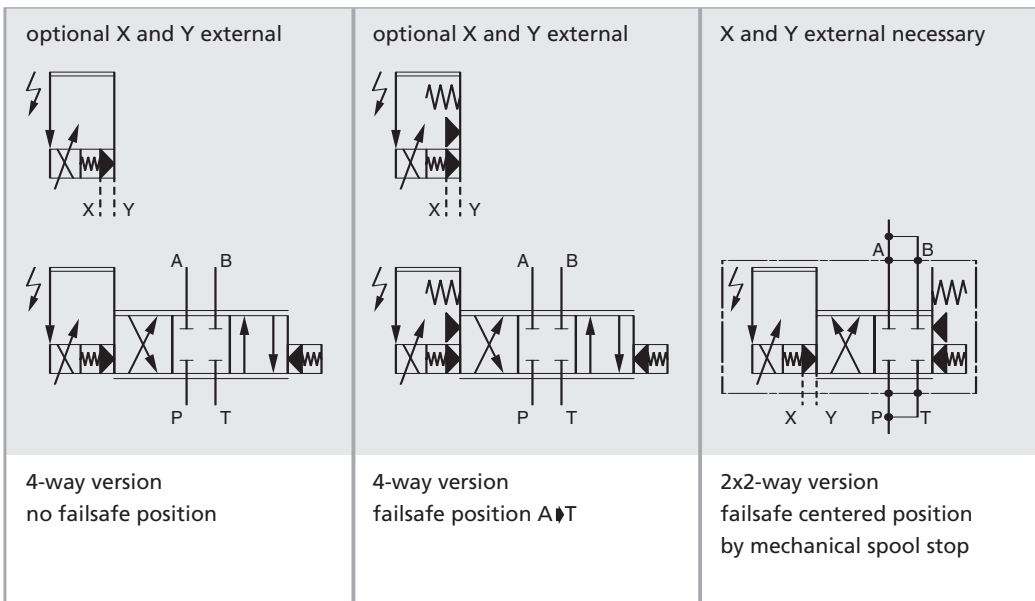

Typical characteristic curves at 210 bar pilot or operating pressure, fluid viscosity of 32 mm²/s and fluid temperature of 40 °C

Flow vs. signal curves
at $\Delta p_N = 5$ bar per land

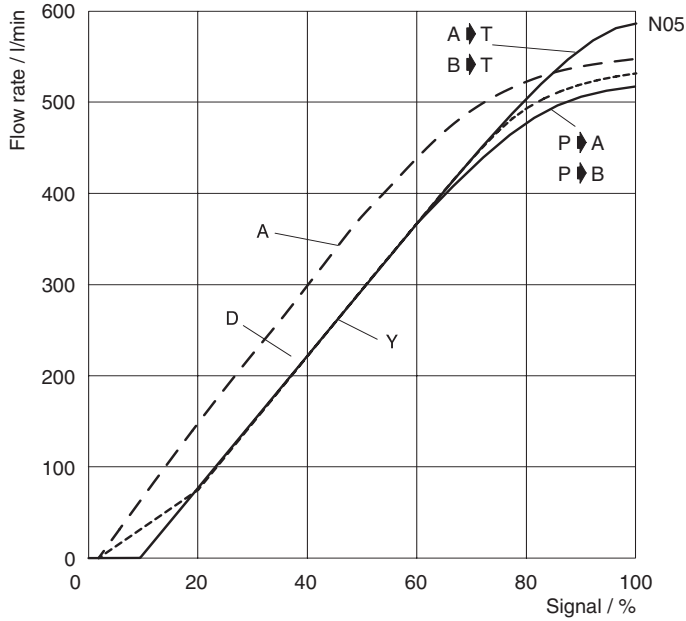

100 l/min = 26.4 gpm	210 bar = 3050 psi
200 l/min = 52.8 gpm	40°C = 104°F
300 l/min = 79.3 gpm	
400 l/min = 106.0 gpm	
500 l/min = 132.0 gpm	
550 l/min = 145.0 gpm	
580 l/min = 153.0 gpm	
600 l/min = 159.0 gpm	

Spool version A: ~critical lap, linear characteristic
 Spool version D: 10 % overlap, linear characteristic
 Spool version Y: ~critical lap, curvilinear characteristic

Step response
D684 - N..H.UO/W

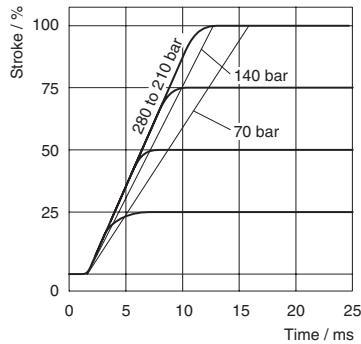

70 bar = 1020 psi
140 bar = 2030 psi
210 bar = 3050 psi
280 bar = 4060 psi

Step response
D684 - N..H.UF/D

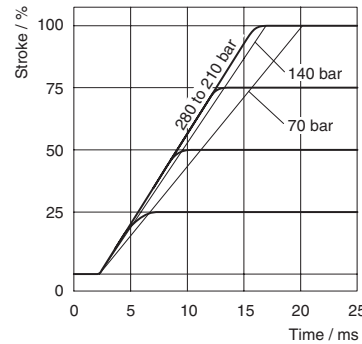

70 bar = 1020 psi
140 bar = 2030 psi
210 bar = 3050 psi
280 bar = 4060 psi

Frequency response
D684 - N..H.UO/W

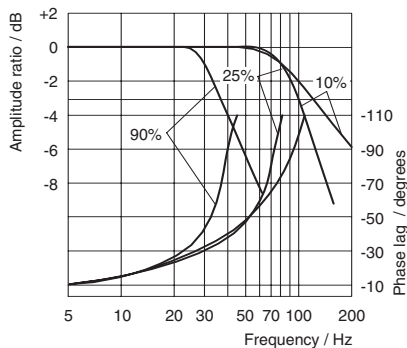

Frequency response
D684 - N..H.UF/D

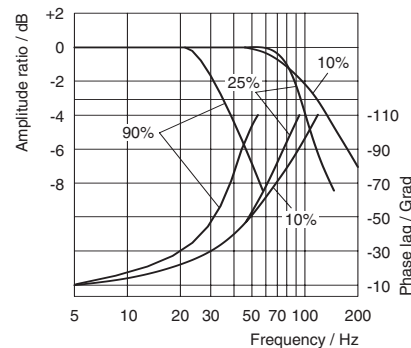

INSTALLATION DRAWING (mm)

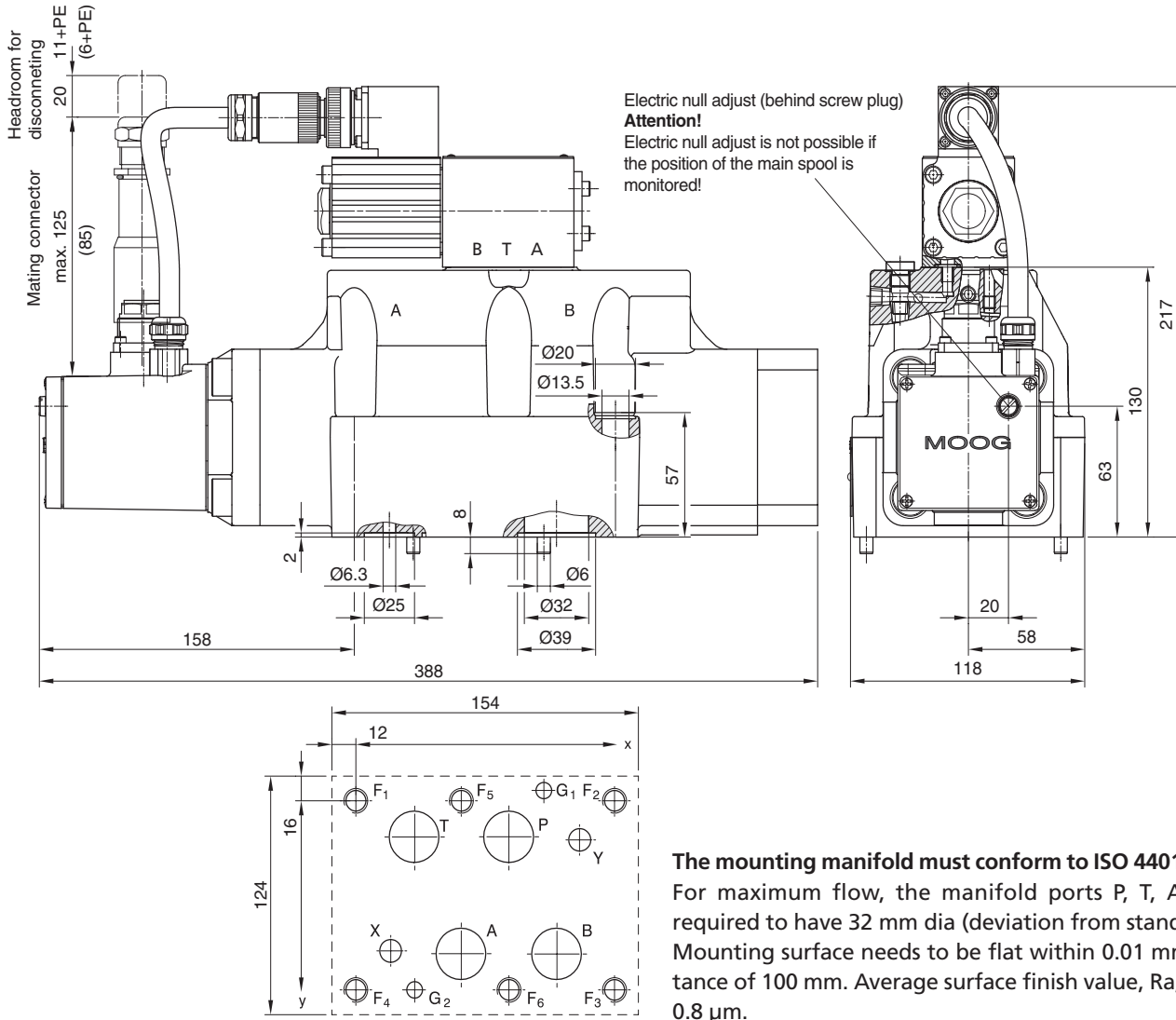

The mounting manifold must conform to ISO 4401-08-07-0-94. For maximum flow, the manifold ports P, T, A and B are required to have 32 mm dia (deviation from standard). Mounting surface needs to be flat within 0.01 mm over a distance of 100 mm. Average surface finish value, Ra, better than 0.8 µm.

mm

	P	A	T	B	X	Y	G ₁	G ₂	F ₁	F ₂	F ₃	F ₄	F ₅	F ₆
	Ø32	Ø32	Ø32	Ø32	Ø11.2	Ø11.2	Ø7.5	Ø7.5	M12	M12	M12	M12	M12	M12
x	77	53.2	29.4	100.8	17.5	112.7	94.5	29.4	0	130.2	130.2	0	53.2	77
y	17.5	74.6	17.5	74.6	73	19	-4.8	92.1	0	0	92.1	92.1	0	92.1

Spare Parts and Accessories

O-rings (included in delivery)		NBR 85 Shore	FPM 85 Shore
for P, T, A, B:	4 pieces ID 34.60 x Ø 2.6	-45122-113	-42082-113
for X, Y:	2 pieces ID 20.29 x Ø 2.6	-45122-195	-42082-195
Mating connector, waterproof IP65 (not included in delivery)		for cable dia	
6+PE-pole	B97007-061	EN175201 Part 804	min. Ø 10 mm, max. Ø 12 mm
11+PE-pole	B97067-111	EN175201 Part 804	min. Ø 11 mm, max. Ø 13 mm
Flushing plate	-76047		
Mounting manifolds	A25855-009		
Mounting bolts (not included in delivery)		required torque	required
M 12 x 75 DIN EN ISO 4762 -10.9	A03665-120-075	94 Nm	6 pieces
Service Seal Kit	B97215	N6X4-25	V6X4-25

INSTALLATION DRAWING (inch)

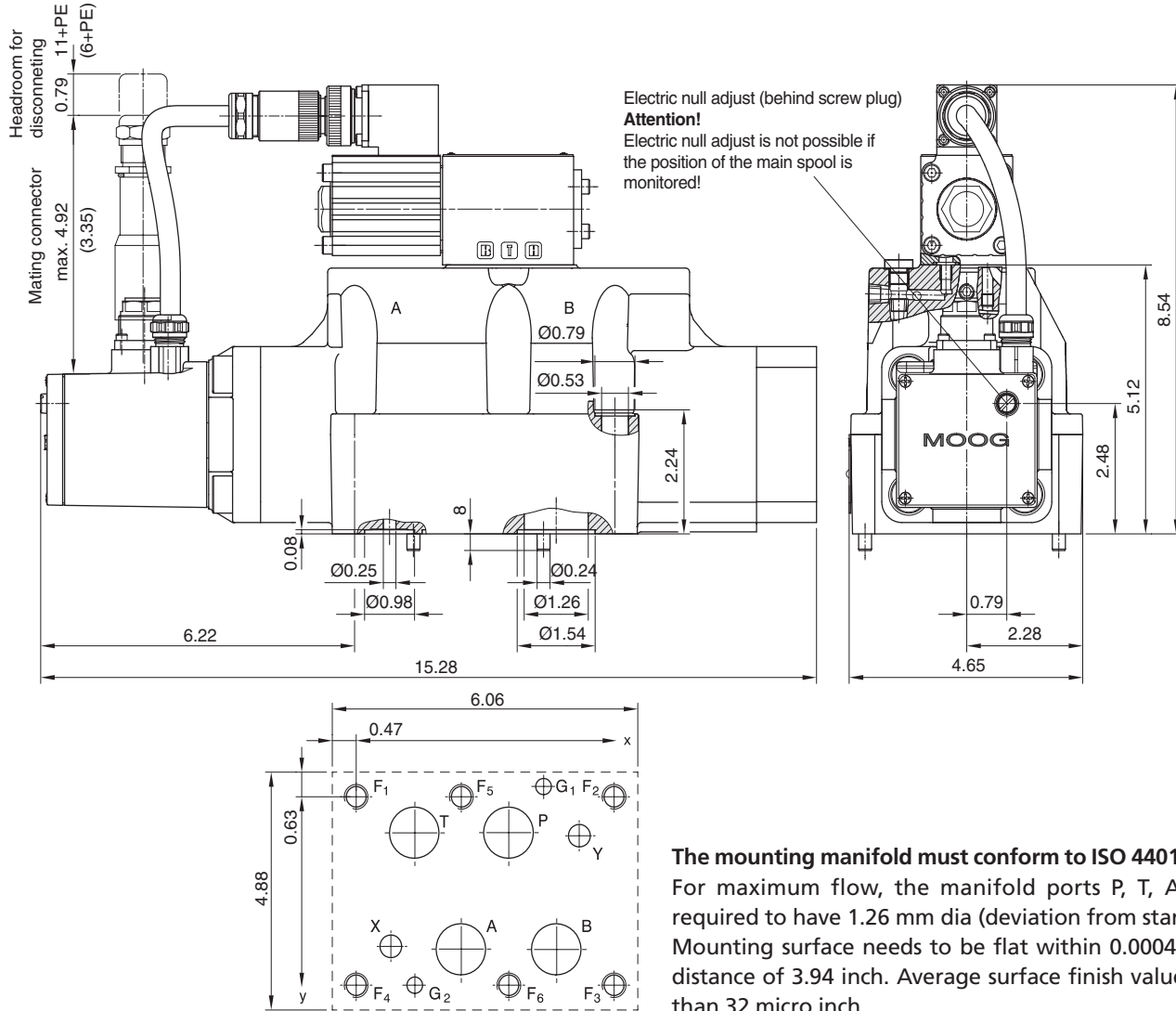

The mounting manifold must conform to ISO 4401-08-07-0-94. For maximum flow, the manifold ports P, T, A and B are required to have 1.26 mm dia (deviation from standard). Mounting surface needs to be flat within 0.0004 inch over a distance of 3.94 inch. Average surface finish value, Ra, better than 32 micro inch.

inch

	P	A	T	B	X	Y	G ₁	G ₂	F ₁	F ₂	F ₃	F ₄	F ₅	F ₆
	Ø1.26	Ø1.26	Ø1.26	Ø0.44	Ø0.44	Ø0.44	Ø0.3	Ø0.3	M12	M12	M12	M12	M12	M12
x	3.03	2.09	1.55	3.97	0.69	4.44	3.72	1.16	0	5.13	5.13	0	2.09	3.03
y	0.69	2.94	0.69	2.94	2.87	0.75	-0.19	3.63	0	0	3.63	3.63	0	3.63

Spare Parts and Accessories

O-rings (included in delivery)		NBR 85 Shore	FPM 85 Shore
for P, T, A, B:	4 pieces ID 1.36 x Ø 0.1	-45122-113	-42082-113
for X, Y:	2 pieces ID 0.8 x Ø 0.1	-45122-195	-42082-195
Mating connector, waterproof IP65 (not included in delivery)		for cable dia	
6+PE-pole	B97007-061	EN175201 Part 804	min. Ø 0.39 in, max. Ø 0.47 in
11+PE-pole	B97067-111	EN175201 Part 804	min. Ø 0.43 in, max. Ø 0.51 in
Flushing plate	-76047		
Mounting manifolds	A25855-009		
Mounting bolts (not included in delivery)		required torque	required
M 12 x 3.0 DIN EN ISO 4762 -10.9	A03665-120-075	70 ft/lbs	6 pieces
Service Seal Kit	B97215	N6X4-25	V6X4-25

Model ... Type			D685 - P10H.T	D685 - P15H.T
Mounting pattern			ISO 4401-10-08-0-94	
Valve version			4-way, 2x2-way 2-stage, stub shaft spool	
Pilot valve	Q_N at $\Delta p_N = 70$ bar (1020 psi)	l/min (gpm)	40 (10.6)	40 (10.6)
Series	D633-1XX (200 N) [889 lbs]		Standard	Standard
Pilot connection			X und Y	X und Y
Mass		kg (lb)	70 (154)	70 (154)
Rated flow	($\pm 10\%$) at $\Delta p_N = 5$ bar per land	l/min (gpm)	1000 (264)	1500 (396)
Operating pressure max.	Ports P, A, B, T and X with Y external	bar (psi)	350 (5080)	350 (5080)
	Ports T with Y internal and Y external (pressure peaks 210 bar (3050 psi))	bar (psi)	50 (725)	50 (725)
Response time*		ms	35	40
Threshold*		%	< 0.03	< 0.02
Hysteresis*		%	< 0.3	< 0.2
Null shift*	at $\Delta T = 55$ K	%	< 2	< 1.5
Null leakage flow*	total max. (~ critical lap)	l/min (gpm)	8.0 (2.1)	8.0 (2.1)
Null leakage flow*	pilot stage only, max.	l/min (gpm)	1.4 (0.37)	1.4 (0.37)
Pilot flow*	max., for 100% step input	l/min (gpm)	40 (10.6)	45 (11.9)
Main spool stroke		mm (in)	± 5.5 (0.22)	± 8.0 (0.31)
Spool drive area		cm ² (in ²)	33.2 (5.14)	33.2 (5.14)

* At 210 bar (3050 psi) pilot or operating pressure, fluid viscosity of 32 mm²/s and fluid temperature of 40 °C (104 °F)

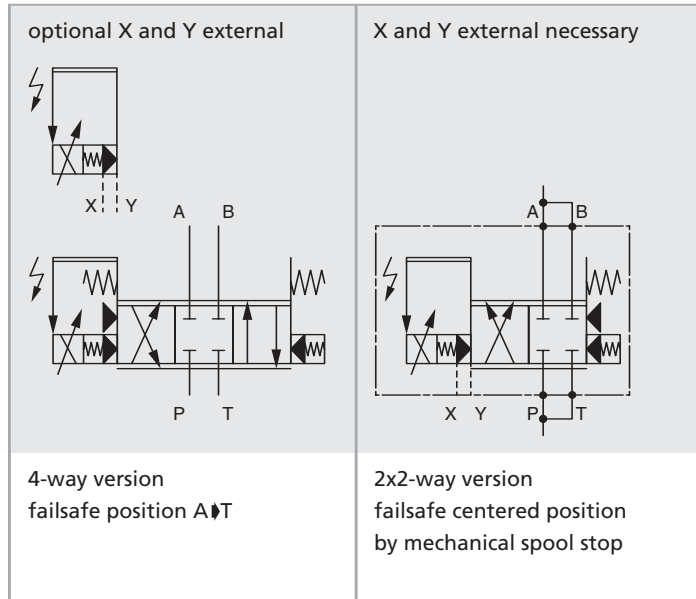

Typical characteristic curves at 210 bar pilot or operating pressure, fluid viscosity of 32 mm²/s and fluid temperature of 40 °C

Flow vs. signal curves
at $\Delta p_N = 5$ bar per land

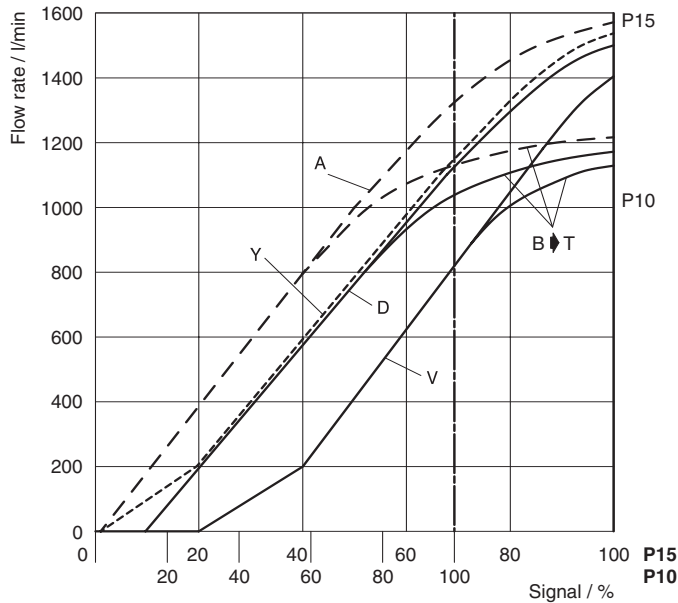

200 l/min = 52.8 gpm	210 bar = 3050 psi
400 l/min = 106.0 gpm	40°C = 104°F
600 l/min = 159.0 gpm	
800 l/min = 211.0 gpm	
1000 l/min = 264.0 gpm	
1200 l/min = 317.0 gpm	
1400 l/min = 370.0 gpm	
1500 l/min = 396.0 gpm	
1600 l/min = 423.0 gpm	

Spool version A: ~critical lap, linear characteristic
 Spool version D: 10 % overlap, linear characteristic
 Spool version Y: ~critical lap, curvilinear characteristic
 Spool version V: ~20 % overlap, curvilinear characteristic

Step response D685 - P10H.T

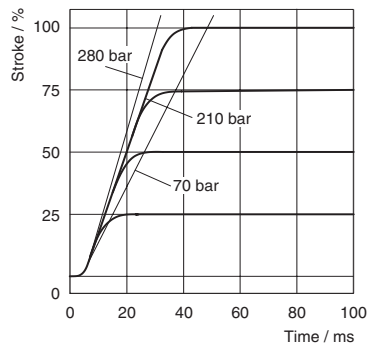

70 bar = 1020 psi
 210 bar = 3050 psi
 280 bar = 4060 psi

Step response D685 - P15H.T

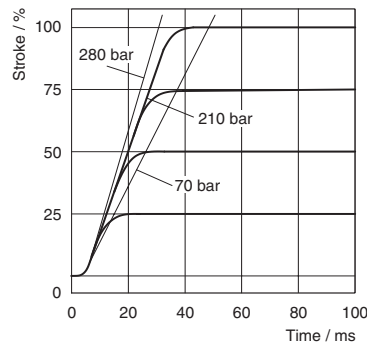

70 bar = 1020 psi
 210 bar = 3050 psi
 280 bar = 4060 psi

Frequency response D685 - P10H.T

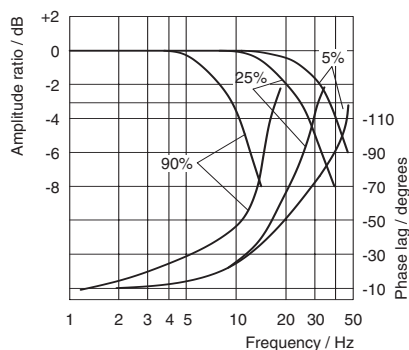

Frequency response D685 - P15H.T

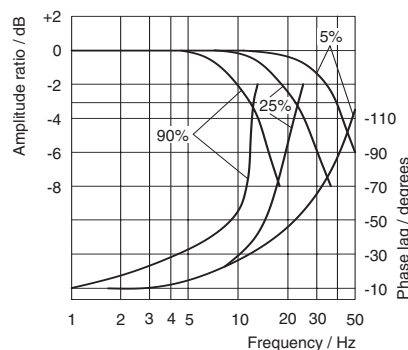

INSTALLATION DRAWING (mm)

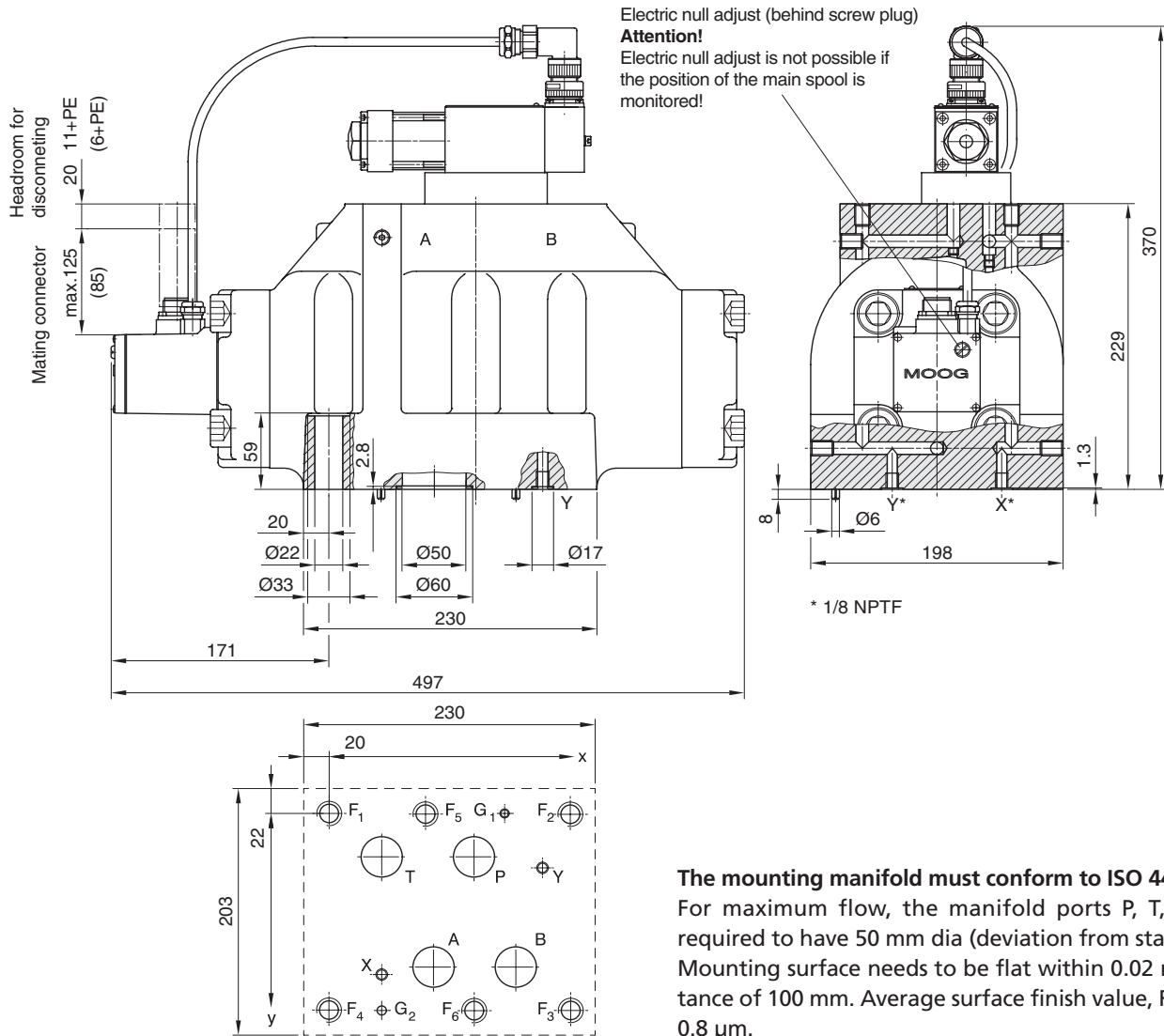

The mounting manifold must conform to ISO 4401-10-08-0-94
 For maximum flow, the manifold ports P, T, A and B are required to have 50 mm dia (deviation from standard).
 Mounting surface needs to be flat within 0.02 mm over a distance of 100 mm. Average surface finish value, Ra, better than 0.8 µm.

mm

	P	A	T	B	X	Y	G ₁	G ₂	F ₁	F ₂	F ₃	F ₄	F ₅	F ₆
	Ø50	Ø50	Ø50	Ø50	Ø11.2	Ø11.2	Ø7.5	Ø7.5	M20	M20	M20	M20	M20	M20
x	114.3	82.5	41.3	147.6	41.3	168.3	147.6*	41.3	0	190.5	190.5	0	76.2	114.3
y	35	123.8	35	123.8	130.2	44.5	0	158.8	0	0	158.8	158.8	0	158.8

* Measurement not according to ISO but to DIN 24340.
 The guard pin G₁ exists in the valve body. The drilling is at 138.6 mm.

Spare Parts and Accessories

Kantseal O-rings (included in delivery)		HNBR 85 Shore	FPM 85 Shore
for P, T, A, B:	4 pieces ID 53.60 x Ø 3.5	B97217-227H	B97217-227V
for X, Y:	2 pieces ID 14.0 x Ø 1.8	B97217-015H	B97217-015V
Mating connector, waterproof IP65 (not included in delivery)			
6+PE-pole	B97007-061	EN175201 Part 804	min. Ø 10 mm, max. Ø 12 mm
11+PE-pole	B97024-111	EN175201 Part 804	min. Ø 11 mm, max. Ø 13 mm
Flushing plate	not available		
Mounting manifolds	A25856-001		
Mounting bolts (not included in delivery)		required torque	required
M 20 x 90 DIN 912-10.9	A03665-200-090	460 Nm	6 pieces
Service Seal Kit	B97215-	S6X5-32	K6X5-32

INSTALLATION DRAWING (inch)

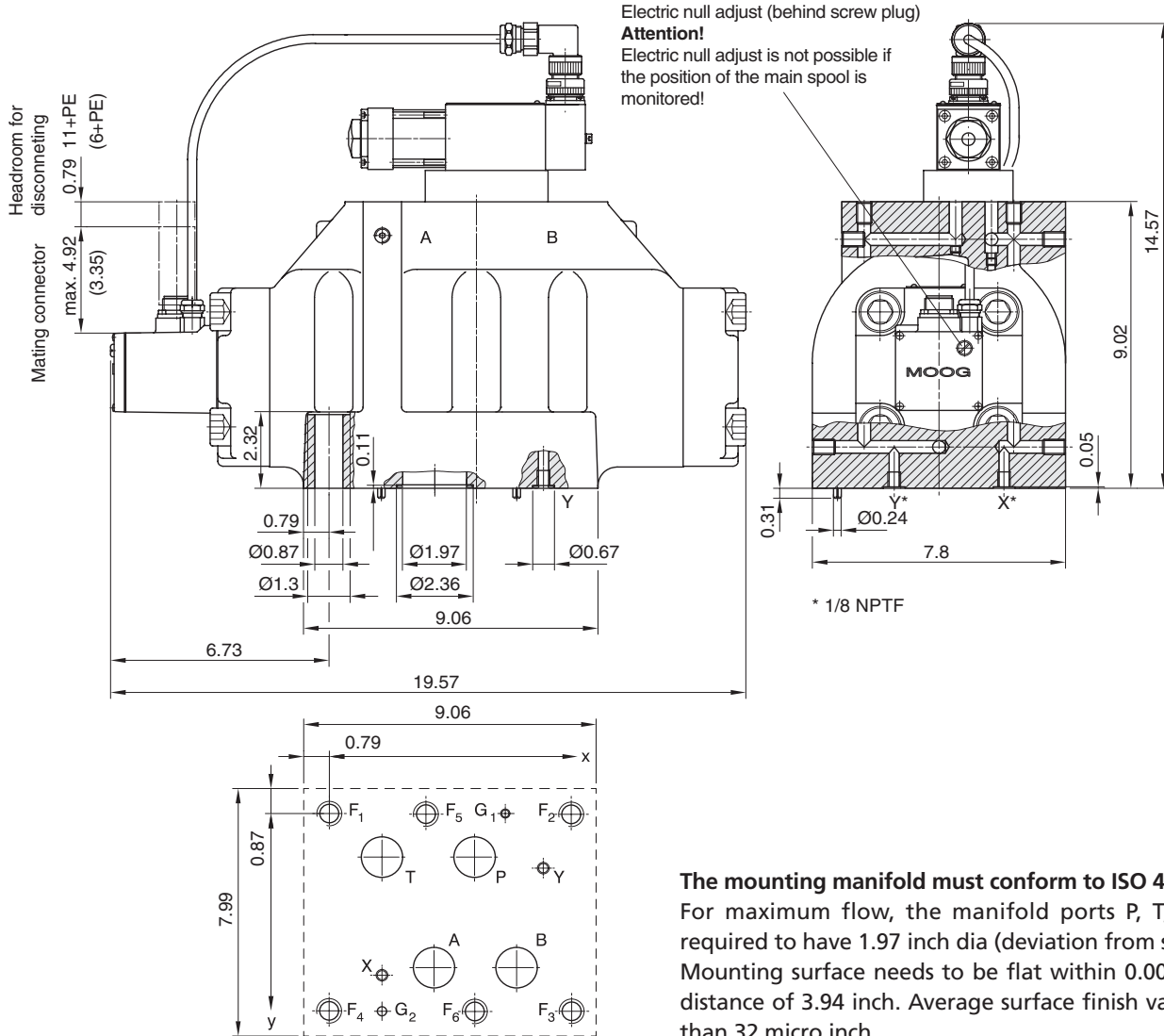

The mounting manifold must conform to ISO 4401-10-08-0-94
 For maximum flow, the manifold ports P, T, A and B are required to have 1.97 inch dia (deviation from standard).
 Mounting surface needs to be flat within 0.0008 inch over a distance of 3.94 inch. Average surface finish value, Ra, better than 32 micro inch.

inch

	P	A	T	B	X	Y	G ₁	G ₂	F ₁	F ₂	F ₃	F ₄	F ₅	F ₆
	Ø1.97	Ø1.97	Ø1.97	Ø1.97	Ø0.44	Ø0.44	Ø0.3	Ø0.3	M20	M20	M20	M20	M20	M20
x	4.5	3.25	1.63	5.81	1.63	6.63	5.81*	1.63	0	7.5	7.5	0	3.0	4.5
y	1.38	4.87	1.38	4.87	5.13	1.75	0	6.25	0	0	6.25	6.25	0	6.25

* Measurement not according to ISO but to DIN 24340.
 The guard pin G₁ exists in the valve body. The drilling is at 5.46 inch.

Spare Parts and Accessories

Kantseal O-rings (included in delivery)		HNBR 85 Shore	FPM 85 Shore
for P, T, A, B:	4 pieces ID 2.11 x Ø 0.14	B97217-227H	B97217-227V
for X, Y:	2 pieces ID 0.55 x Ø 0.07	B97217-015H	B97217-015V
Mating connector, waterproof IP65 (not included in delivery)			
6+PE-pole	B97007-061	EN175201 Part 804	min. Ø 0.39 in, max. Ø 0.47 in
11+PE-pole	B97024-111	EN175201 Part 804	min. Ø 0.43 in, max. Ø 0.51 in
Flushing plate	not available		
Mounting manifolds	A25856-001		
Mounting bolts (not included in delivery)		required torque	required
M 20 x 3.6 DIN 912-10.9	A03665-200-090	340.4 ft/lbs	6 pieces
Service Seal Kit	B97215-	S6X5-32	K6X5-32

VALVES FOR APPLICATIONS WITH SAFETY REQUIREMENTS (FAILSAFE) WITH 11+PE CONNECTOR

For applications with proportional control valves where certain safety regulations are applicable, a safe metering spool position is needed in order to avoid potential damage. Therefore, a failsafe version is offered as an option for the multi-stage Moog Proportional Control Valves. After switching off the 24 V supply to the safety solenoid valve, this failsafe function causes a safe metering spool position, overlapped centered position or fully opened A↗T or B↘T. In order to move the spool to the safe centered position with D680 Series failsafe valves, the two control chambers of the main stage are hydraulically short circuited via a 4/2-way solenoid valve. The spring force moves the spool into the overlapped centered position.

In order to reach the fully opened position A↗T with D680 Series failsafe valves, the spring force (after the control chambers have been short circuited) pushes the spool to the end position A↗T or B↘T.

With failsafe valves, it is possible to check whether the main spool is in safe position. If the main spool is within the defined safe range, the logic output signal at pin 11 is > + 8.5 V. If this signal is < + 6.5 V, then the main spool is outside the safe range. This logic signal may be delayed up to 500 ms. To reduce the failsafe switching time, it is advised to both switch off the supply of the 4/2-way valve and the enable signal at the same time.

NOTE:

According to DIN-EN 954-1, a higher safety category can be achieved if a failsafe valve is used.

ELECTRIC CHARACTERISTICS

4/2-way solenoid valve for the failsafe version.
For more information on failsafe versions, see Moog Application Note AM 423 E.

Valve version	4/2-way solenoid valve
Function	electro magnetic
Nominal voltage U_N	24 V DC (min. 22.8 V DC, max. 26.4 V DC)
Nominal power I_N	1.35 A
Nominal power P_N	33 W

Connector wiring

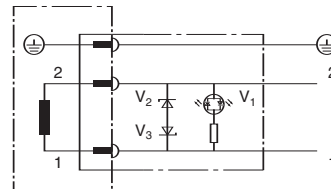

DIN EN 175301 Part 803
with free wheel- and light diode

D683/D684 SERIES 2-STAGE PROPORTIONAL CONTROL VALVE WITH D633-7... SERIES PILOT VALVE AND 4/2-WAY SOLENOID VALVE FOR THE FAILSAFE VERSION

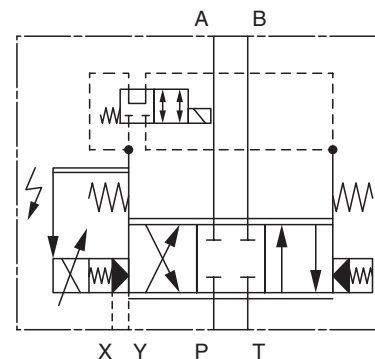
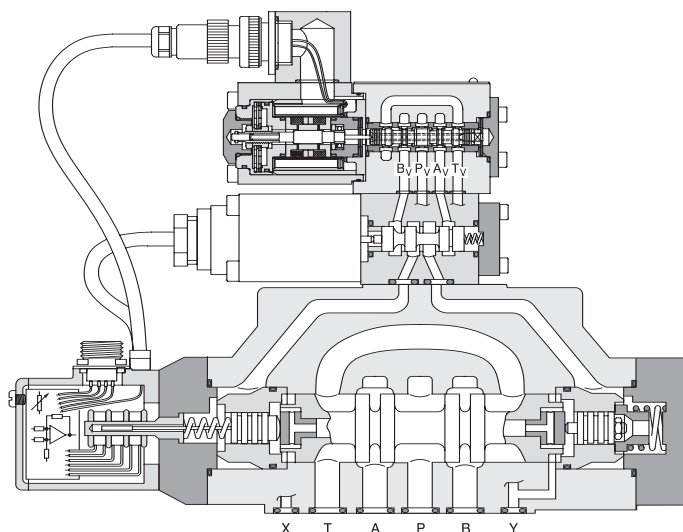

Hydraulic symbol:
Symbol shown with pilot pressure; electric supply on and solenoid valve magnet off.

FAILSAFE VALVE ELECTRONICS WITH SUPPLY VOLTAGE 24 VOLT AND 11+PE POLE CONNECTOR

Command signal 0 to ±10 mA floating

Valves with current command input

The spool stroke of the valve is proportional to $I_4 = -I_5$.
 100% valve opening P \blacktriangleright A and B \blacktriangleright T is achieved at $I_4 = +10$ mA.
 At 0 mA command, the spool is in centered position.
 The input pins 4 and 5 are inverting. Either pin 4 or 5 is used according to the required operating direction. The other pin is connected to signal ground at cabinet side.

Command signal 0 to ±10 V

Valves with voltage command input

The spool stroke of the valve is proportional to $(U_4 - U_5)$.
 100% valve opening P \blacktriangleright A and B \blacktriangleright T is achieved at $(U_4 - U_5) = +10$ V.
 At 0 V command, the spool is in centered position.
 The input stage is a differential amplifier. If only one command signal is available, pin 4 or 5 is connected to signal ground at cabinet side according to the required operating direction.

Actual value 4 to 20 mA

The actual spool position value can be measured at pin 6 (see diagram on the top). This signal can be used for monitoring and fault detection purposes.
 The spool stroke range corresponds to 4 to 20 mA.
 The centered position is at 12 mA. 20 mA corresponds to 100% valve opening P \blacktriangleright A and B \blacktriangleright T.

Circuit diagram for measurement of actual value I_6 (position of main spool) for valves with 11 + PE pole connector (signal "M and X")

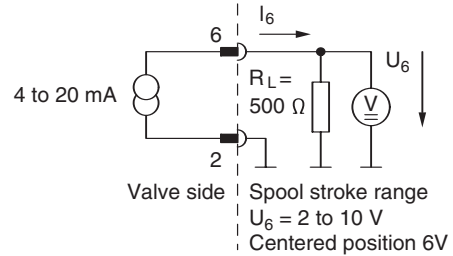

(Signal type "D" R_L integrated on electronics)

The position signal output 4 to 20 mA allows to detect a cable break when $I_6 = 0$ mA. For failure detection purposes, it is advised to connect pin 6 of the mating connector and route this signal to the control cabinet.

Note: Enable input

With enable signal off, the main spool will move to a safe position. Spool position $\pm 3\%$.

- a) Defined centered position. (Unbiased pilot valve). Function code A¹⁾.
- b) End position (Biased pilot valve). Function code B¹⁾.

¹⁾ see type designation

GENERAL REQUIREMENTS

- Supply 24 V DC, min. 18 VDC, max. 32 VDC
 Current consumption max. 800 mA
 Additional supply 24 V DC failsafe valve and current consumption 1.35 A to pin 9 \blacktriangleright 10.
- All signal lines, also those of external transducers, shielded.
- Shielding connected radially to \perp (0 V), power supply side, and connected to the mating connector housing (EMV).
- **EMV:** Meets the requirements of EN55011:1998+A1:1999 (limit class: B) and immunity according to EN61000-6-2:1999

- Minimum cross-section of all leads ≥ 0.75 mm² (AWG 18). Consider voltage losses between cabinet and valve.
- Note: When making electric connections to the valve (shield, protective earth) appropriate measures must be taken to ensure that locally different earth potentials do not result in excessive ground currents.
 Also see Moog Technical Note TN353.

WIRING FOR VALVES WITH 11+PE POLE CONNECTOR WITH INTEGRATED SOLENOID VALVE ELECTRICAL PANEL SUPPLY

To EN 175201 Part 804, and mating connector (type E, metal shell) with leading protective earth connection (⊥).

Also see wiring instructions (on page 40). Logic function G and H.

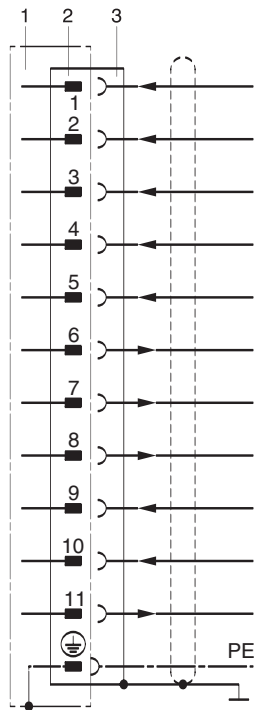

Function	Voltage command	Current command
1 Supply	24 V DC (min. 18 V DC, max. 32 V DC)	Static: $I_{max.}: 200 \text{ mA}$ Dynamic: $I_{max.}: 800 \text{ mA}$
2 Supply / Signal ground	⊥ (0 V)	
3 Enabled Not enabled	$U_{3-2} > +8.5 \text{ V DC}$ $U_{3-2} < +6.5 \text{ V DC}$ $I_e = 2,0 \text{ mA}$ at 24 V DC, max. 32 V DC	
4 Input rated command 5 (differential)	$U_{4-5} = 0 \text{ to } \pm 10 \text{ V}$ $R_e = 10 \text{ k}\Omega$	Input command $I_4 = -I_5: 0 \text{ to } \pm 10 \text{ mA}$ ($R_e = 200 \Omega$)
6 Output actual value spool position	Inputs U_{4-2} and U_{5-2} for both signal types limited to min. -15 V and max. $+32 \text{ V}$ $I_{6-2} = 4 \text{ to } 20 \text{ mA}$. At 12 mA spool is in centered position. $R_l = 100 \text{ to } 500 \Omega$ Signal code D: $U_{6-2} = 2 \text{ to } 10 \text{ V}$. At 6 V spool is in centered position. $R_a = 500 \Omega$	
7 Auxiliary signal	Spool position $U_{7-2} = 13 \text{ to } 3 \text{ V}$. At 8 V spool is in centered position. $R_a = 5 \text{ k}\Omega$	
8 Valve ready	$U_{8-2} > +8.5 \text{ V DC}$: Enable and supply ok $U_{8-2} < +6.5 \text{ V DC}$: Not enabled or supply not ok	Output $I_{max.}: 20 \text{ mA}$
9 Supply 4/2-way solenoid valve	24 V DC (min. 22,8 V DC, max. 26,4 V DC, max. 1.35 A)	
10 Supply, 4/2-way solenoid valve, signal ground	⊥ (0 V)	
11 Position monitoring Safe position, logic	$U_{11-2} > +8.5 \text{ V DC}$: safety position $U_{11-2} < +6.5 \text{ V DC}$: not safety position	Output $I_{max.}: 20 \text{ mA}$
⊕ Protective earth		

- 1 Valve
- 2 Connector
- 3 Mating connector

Additional information on command signal on page 40.

INSTALLATION DRAWING (mm)

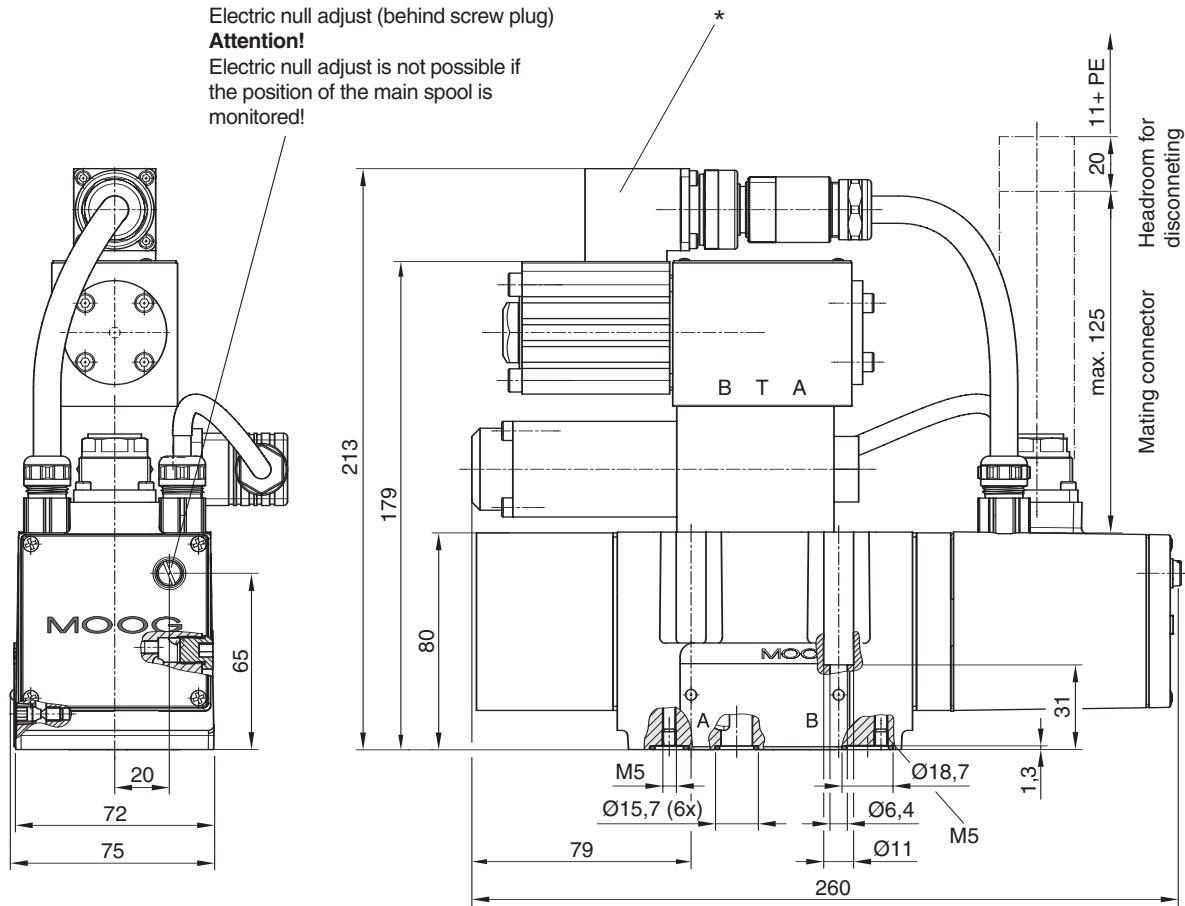

* Valves with spool position monitoring in type designation letter G and H, no pilot valve change possible. Replacement must be done at the factory. The mounting manifold must conform to ISO 4401 - 05 - 05 - 0 - 94 (see page 10).

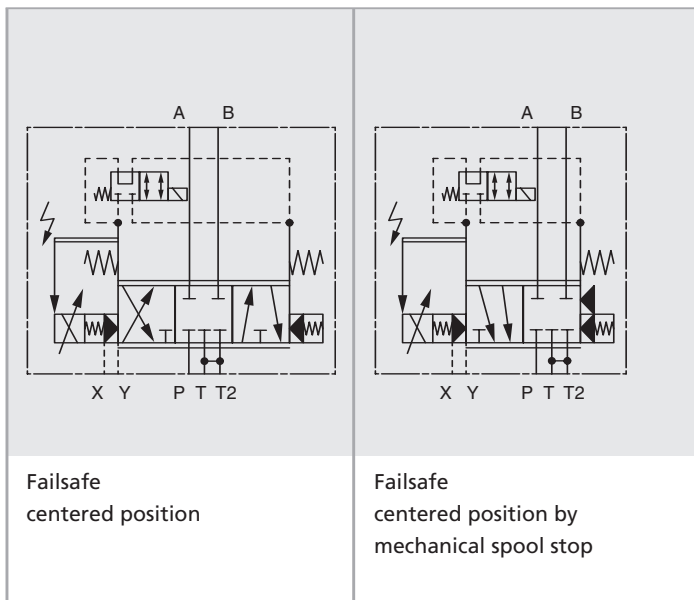

See Spare Parts and Accessories on page 10.

INSTALLATION DRAWING (inch)

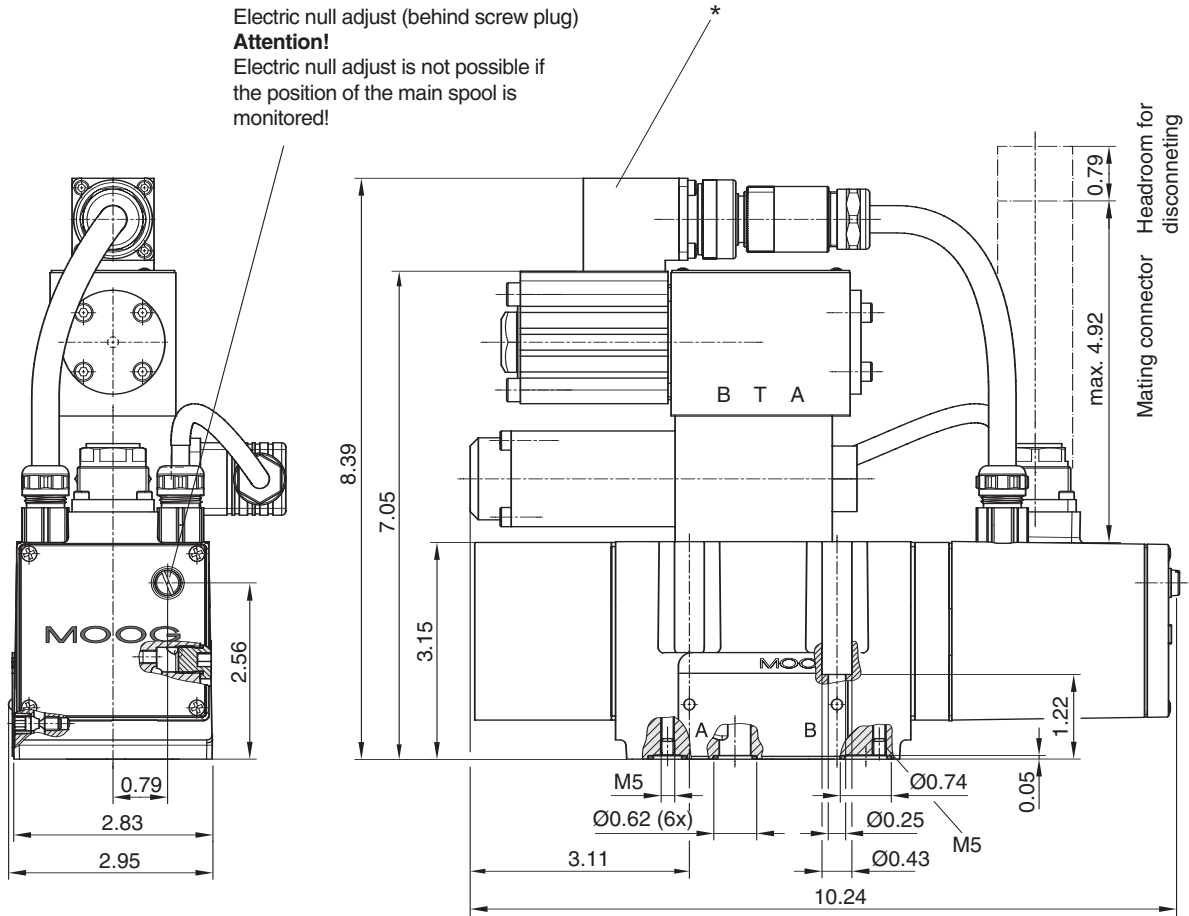

* Valves with spool position monitoring in type designation letter G and H, no pilot valve change possible. Replacement must be done at the factory. The mounting manifold must conform to ISO 4401 - 05 - 05 - 0 - 94 (see page 11).

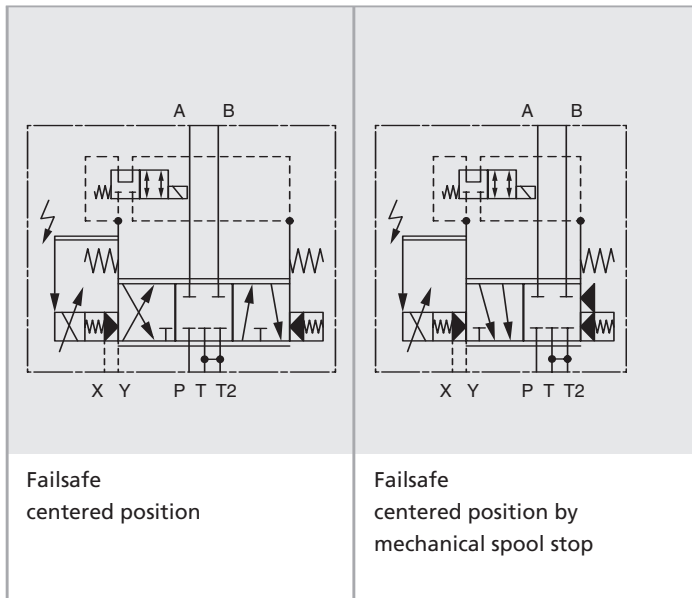

See Spare Parts and Accessories on page 10.

INSTALLATION DRAWING (mm)

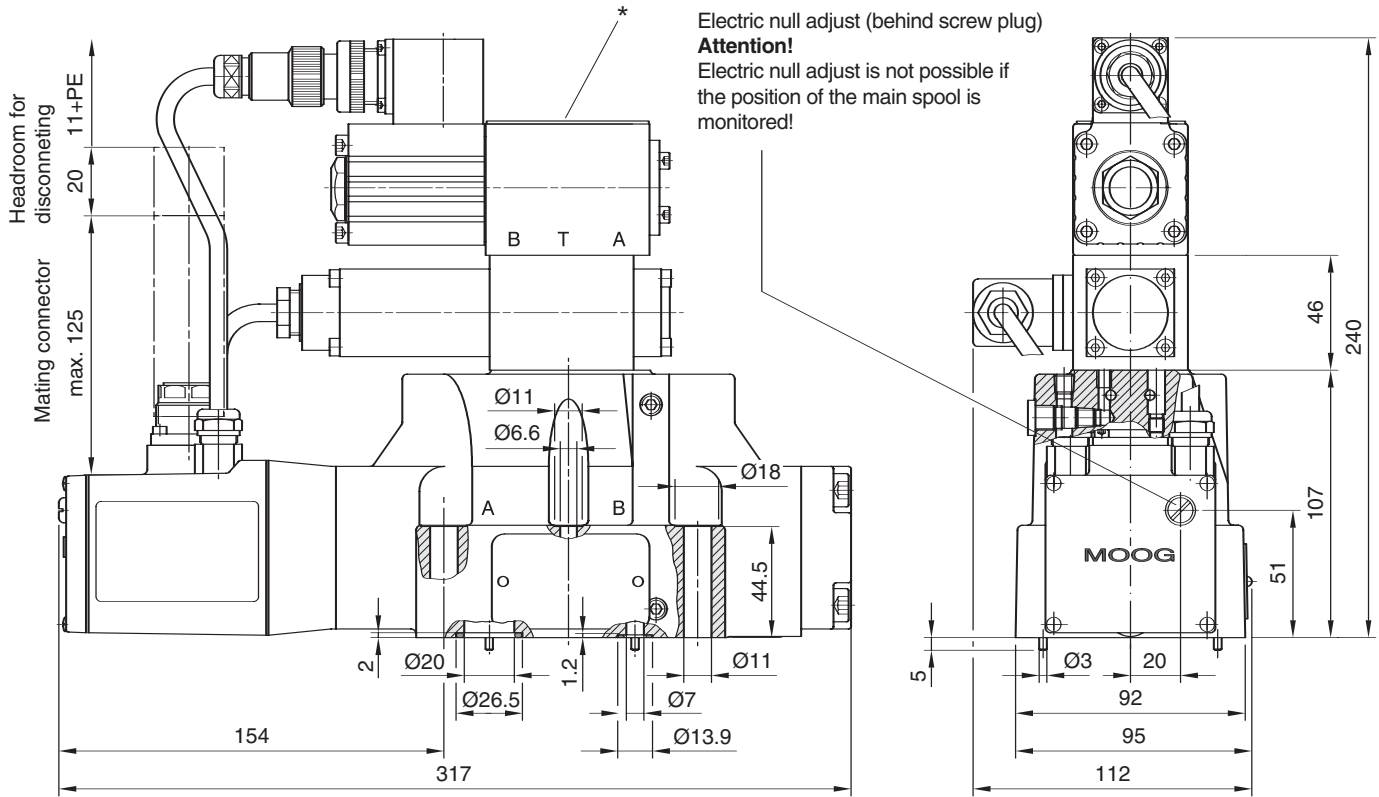

* Valves with spool position monitoring in type designation letter G and H, no pilot valve change possible. Replacement must be done at the factory. The mounting manifold must conform to ISO 4401-07-06-0-94 (see page 14).

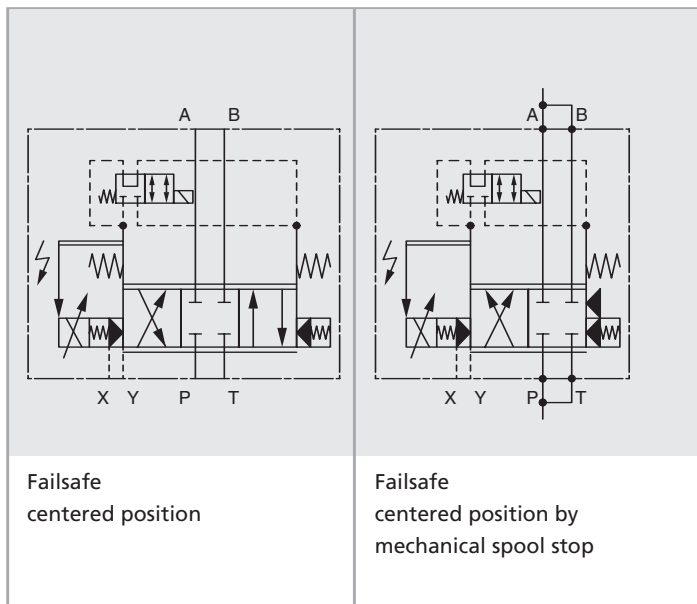

See Spare Parts and Accessories on page 14.

INSTALLATION DRAWING (inch)

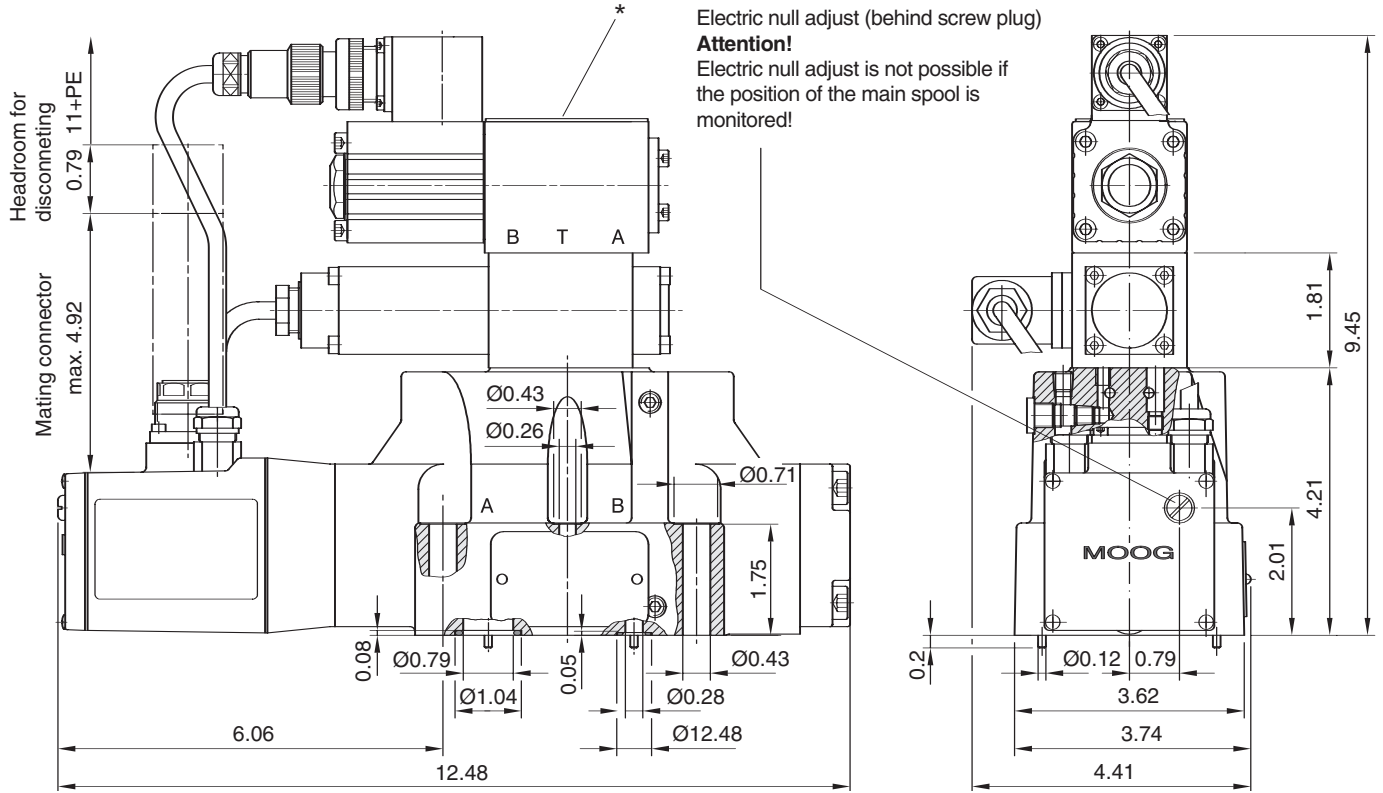

* Valves with spool position monitoring in type designation letter G and H, no pilot valve change possible. Replacement must be done at the factory. The mounting manifold must conform to ISO 4401-07-06-0-94 (see page 15).

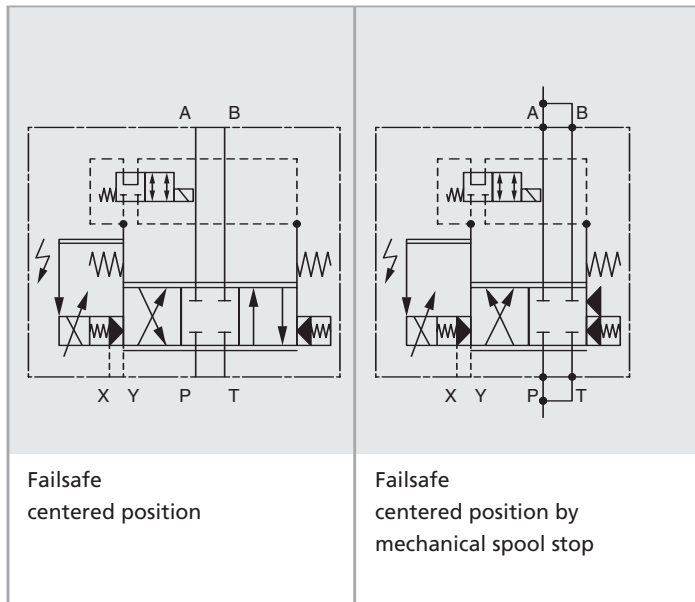

See Spare Parts and Accessories on page 14.

INSTALLATION DRAWING (mm)

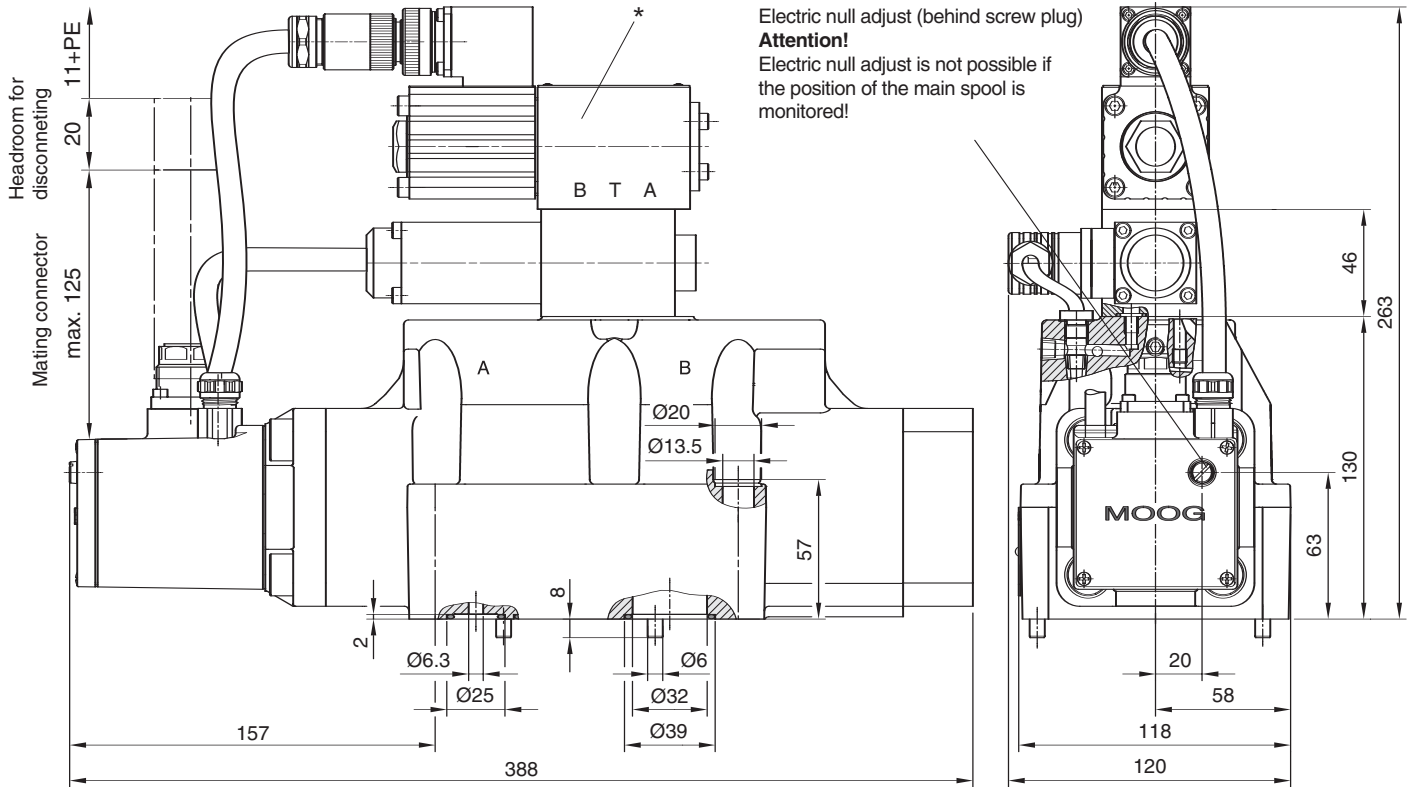

* Valves with spool position monitoring in type designation letter G and H, no pilot valve change possible. Replacement must be done at the factory. The mounting manifold must conform to ISO 4401-08-07-0-94 (see pages 18 and 22).

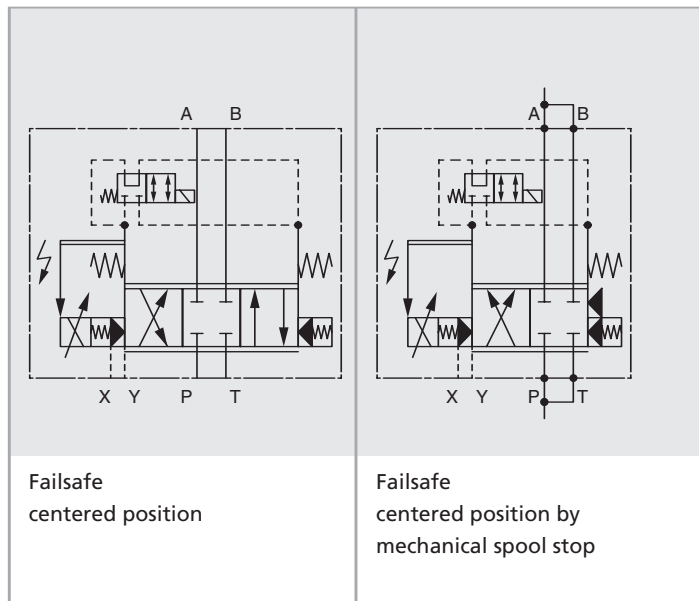

See Spare Parts and Accessories on page 18 and 22.

INSTALLATION DRAWING (inch)

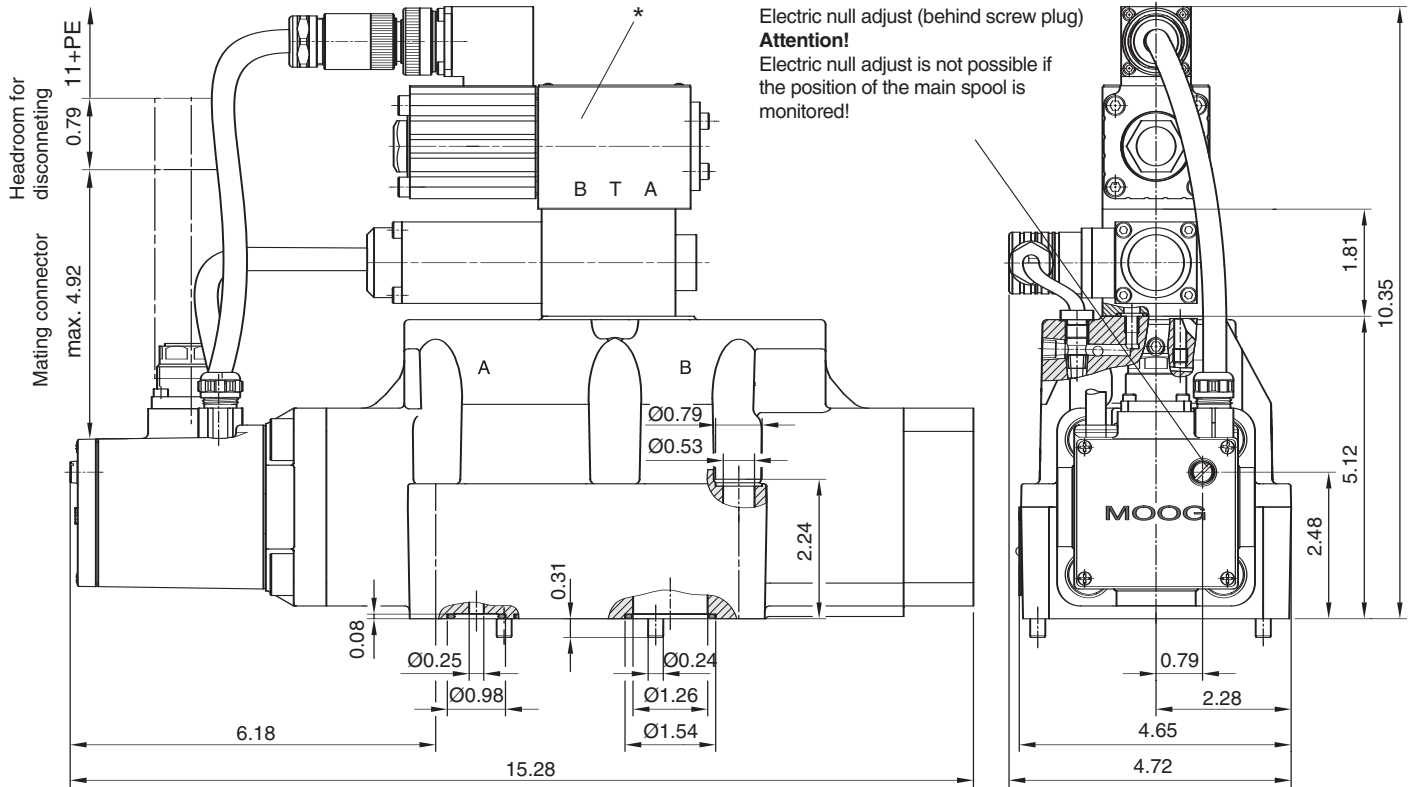

* Valves with spool position monitoring in type designation letter G and H, no pilot valve change possible. Replacement must be done at the factory. The mounting manifold must conform to ISO 4401-08-07-0-94 (see pages 19 and 23).

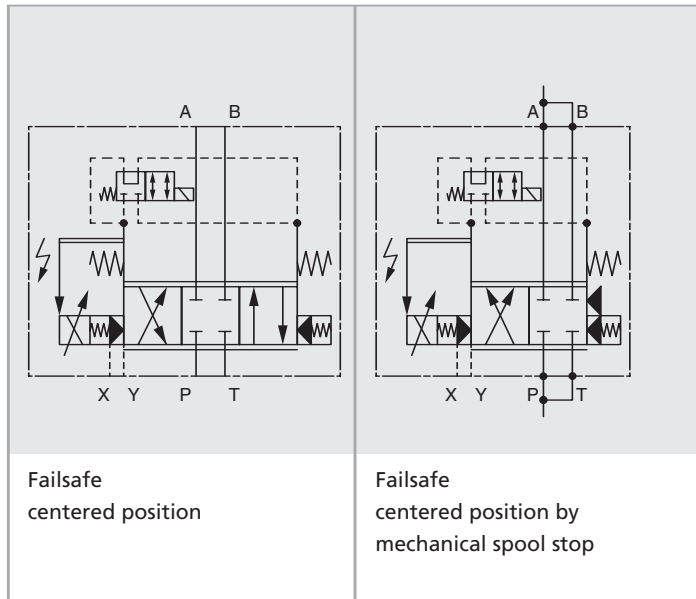

See Spare Parts and Accessories on page 19 and 23.

INSTALLATION DRAWING (mm)

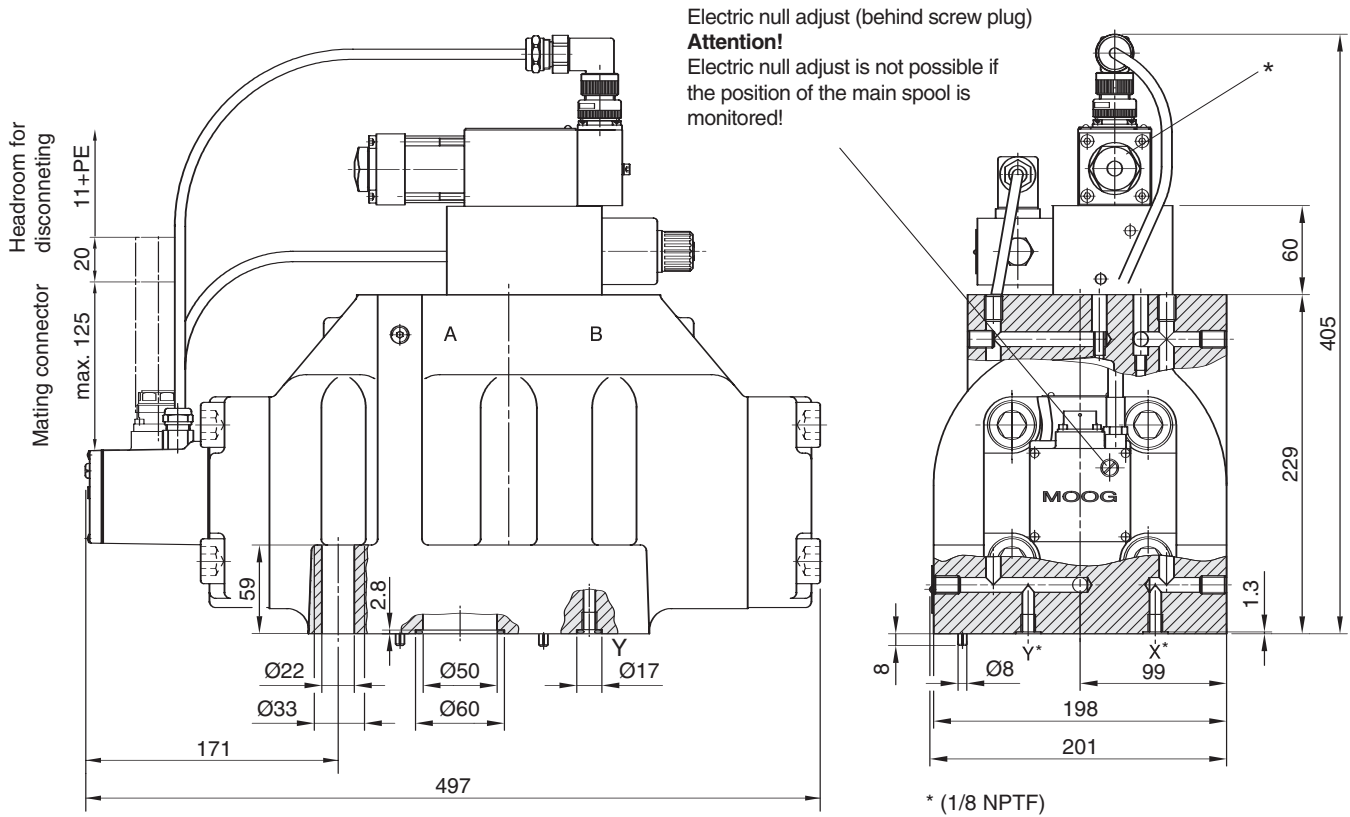

* Valves with spool position monitoring in type designation letter G and H, no pilot valve change possible. Replacement must be done at the factory. The mounting manifold must conform to ISO 4401-08-07-0-94 (see page 26).

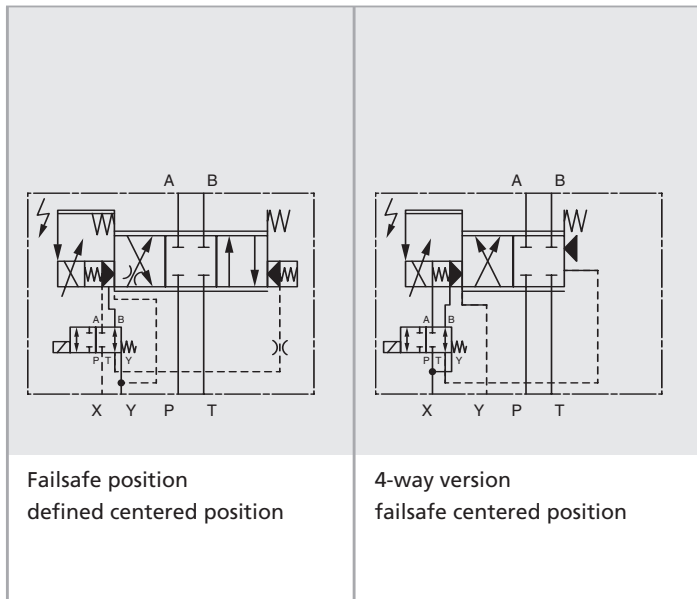

See Spare Parts and Accessories on page 26.

INSTALLATION DRAWING (inch)

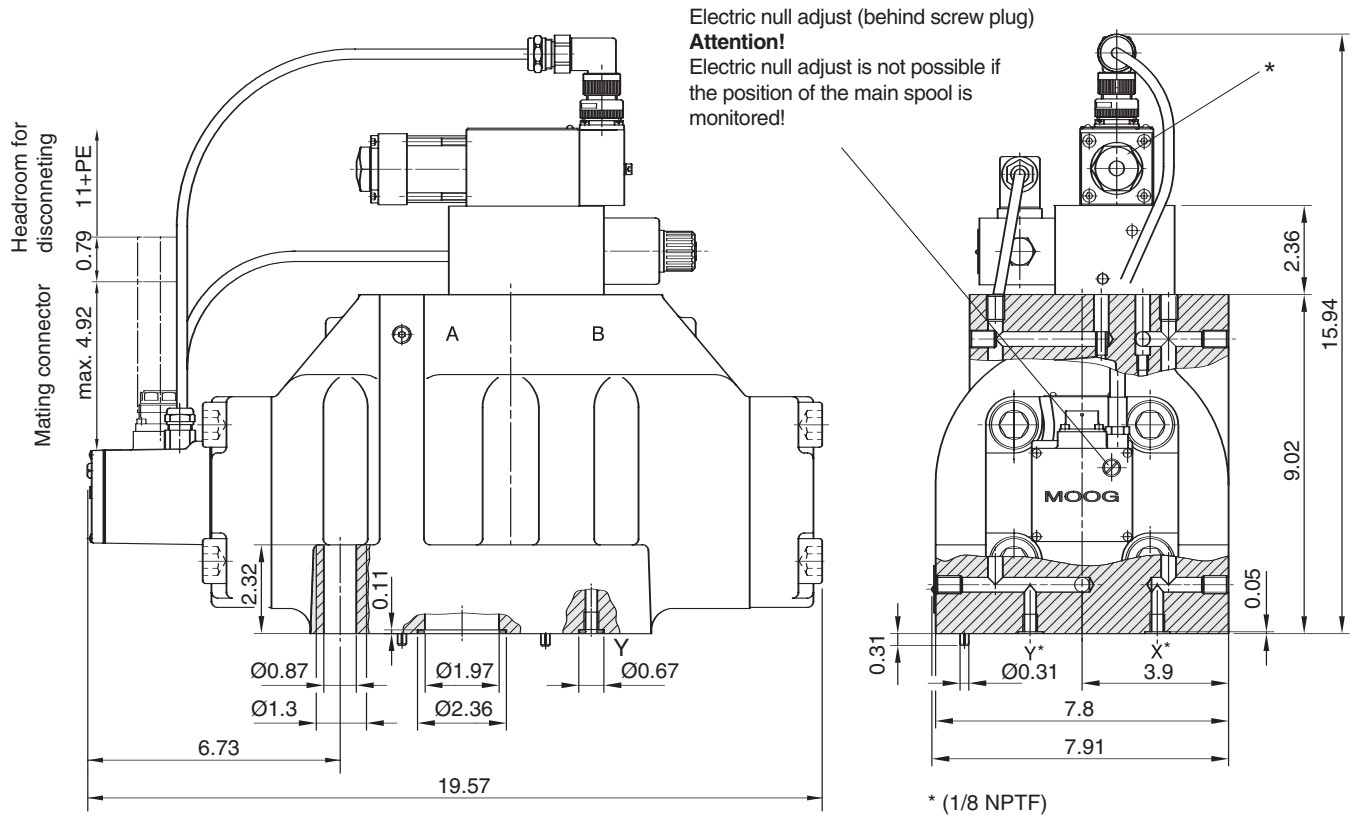

* Valves with spool position monitoring in type designation letter G and H, no pilot valve change possible. Replacement must be done at the factory. The mounting manifold must conform to ISO 4401-08-07-0-94 (see page 27).

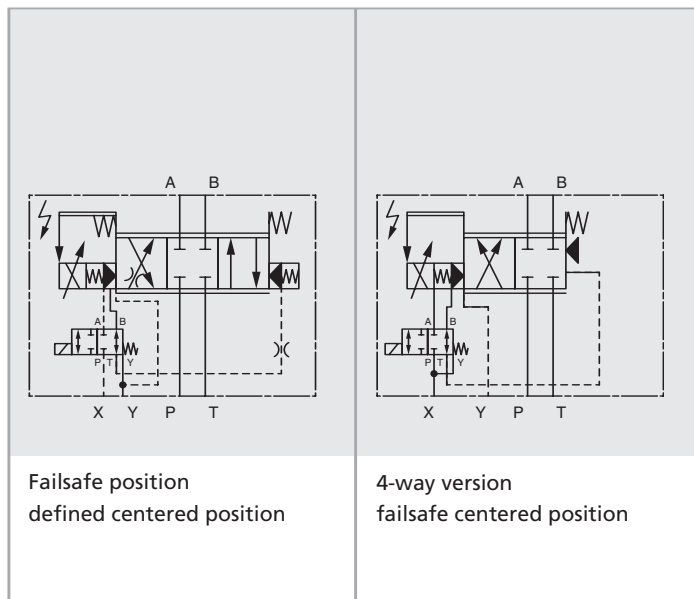

See Spare Parts and Accessories on page 27.

SINGLE ANALOG INPUT 6+PE AND 11+PE

0 to ± 10 mA floating input signal

The spool stroke of the valve is proportional to $I_{D(4)} = -I_{E(5)}$.
 At $I_{D(4)} = +10 \text{ mA}$, command signal the valve is 100% P↗A and B↘T.
 At $I_{D(4)} = 0 \text{ mA}$, the spool is in the defined centered position.

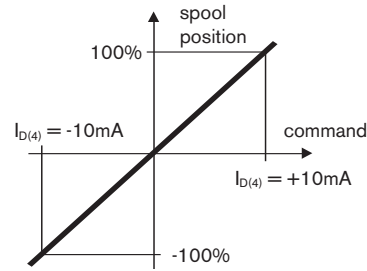

Position signal curve

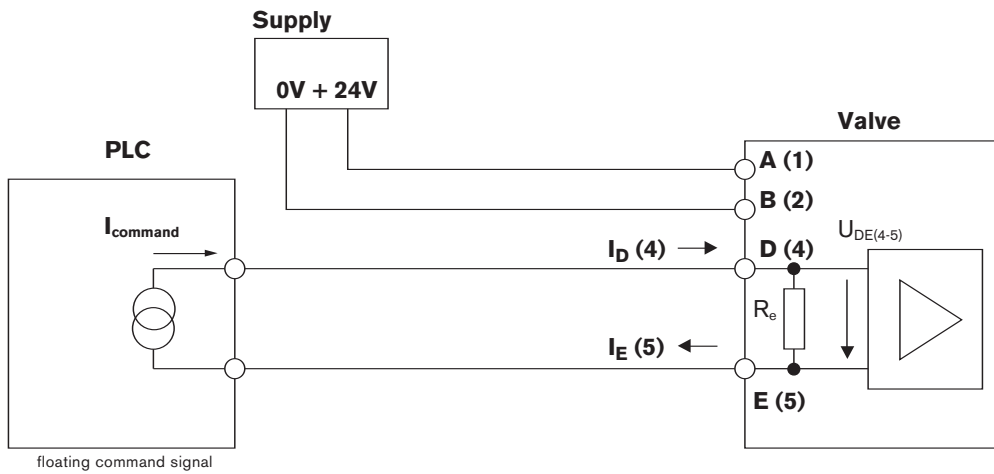

0 to ± 10 V differential input signal

The spool stroke of the valve is proportional to $U_{D(4)}$.
 $U_{D(4)} = +10 \text{ V}$ input moves spool 100% P↗A and B↘T.
 At nominal value $U_{D(4)} = 0 \text{ V}$, spool in defined centered position.

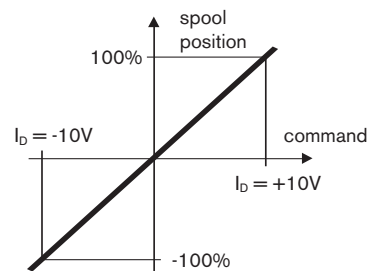

Position signal curve

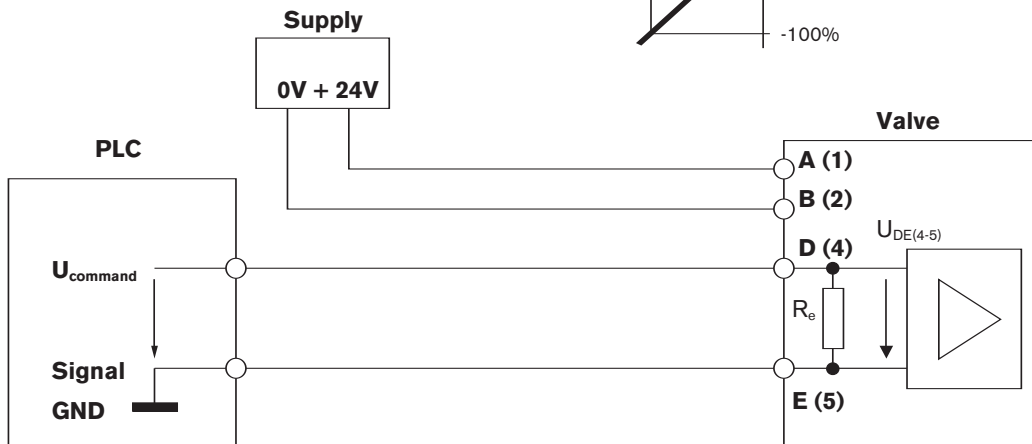

D681 to D685 Model-Number Type designation

. **2** - .

Specification status	
-	Series specification
E	Preseries specification
Z	Special specification

Model designation	
	assigned at the factory

Factory identification

Valve version		Series
B	Standard 5 way	D681 (+P ₂)
P	Standard spool ¹	D681 and D682/D685
N	Stub shaft spool Ø 25 mm	D683 and D684

Rated flow			
	Q _N [l/min] (gpm) at Δp _N = 5 bar (75 psi) per land	Series	
30	30 (7.9)	D681	
60	60 (15.9)	D681	
80	80 (21.1)	D681	
01	150 (39.5)	D682	
02	250 (65.8)	D682	
03	350 (92.1)	D683	
05	550 (144.7)	D684	
10	1000 (263.1)	D685	
15	1500 (394.7)	D685	

Maximum operating pressure p _p	
B	70 bar } Pilot valve D633-X ..., p _{max.} = 350 bar
H	280 bar } The integrated valve electronics is adapted
K	350 bar } to the pilot pressure.

Main spool type	
A	4-way: ~ Critical lap, linear characteristic
D	4-way: 10 % overlap, linear characteristic
P	4-way: P↗A, A↘T: ~ critical lap, curvilinear characteristic P↗B: 60 % overlap, curvilinear characteristic B↘T: 50 % underlap, linear characteristic
U	5-way: P↗A, P ₂ ↗B, A↘T: ~ critical lap, curvilinear characteristic (D681-B only)
R	4-way: 10 % overlap, curvilinear characteristic
Y	4-way: ~ Critical lap, curvilinear characteristic
Z	2x2-way: A↗T, B↘T ₂ : ~ critical lap, linear characteristic D681 P↗T, T↘A, D682-D685
X	Special spool upon request

Direct Drive pilot valve		Series
U	D633-7... // (80 N Linear motor)	D681-D684
T	D633-1... (200 N Linear motor)	D685
X	Special valve version upon request	

¹ Optional D683-P and D684-P
² WV directional valve
³ VEL valve electronics

For special options, letters not on the information above may be applied. Options may increase price. All combinations may not be available. Preferred configurations are highlighted. Technical changes are reserved.

Function code		Connector
O	No enable input. Pin C not used.	S
A	Without enable signal applied, the spool moves to adjustable centered position.	S
B	Without enable signal, the spool moves into defined end position A↗T or B↘T.	S
J	Without enable signal applied, the spool moves to adjustable centered position. Position error monitored (see page 29/30).	E
G	Without enable signal applied, the spool moves to adjustable centered position. Spool position monitored (see page 29/30).	E
H	Without enable signal applied, the spool moves into defined end position A↗T or B↘T. Spool position monitored (see page 29/30).	E

Supply voltage	
2	24 V DC (18 to 32 V DC)

Signals for 100% spool stroke			
	Command	Output	Connector
A	± 10 V	± 10 V (diff.)	E
D	± 10 V	2 to 10 V	E / S
M	± 10 V	4 to 20 mA	E / S
T	± 10 V	± 10 V (diff.) with dead band compens.	E
X	± 10 mA	4 to 20 mA potential free nom. value	E / S
Y	Others upon request		

Valve connector	
E	11 + PE pole EN 175201-804
S	6 + PE pole EN 175201-804

Seal material	
N	NBR (Buna) Standard
V	FPM (Viton) Special version
S	HNBR-D685-P (Standard)
X	Others upon request

Pilot connections and pilot pressure			
	Supply X	Return Y	
4	Internal	Internal	Parameters of the control electronics are adapted to the pilot pressure. See operating pressure on the nameplate and in this ordering information.
5	External	Internal	
6	External	External	
7	Internal	External	

Spool position of main stage with/without electric or hydraulic supply					
O	Undefined (no failsafe function)				
Mechanical failsafe version					
	Position	p _p or p _x external [bar]			
F	P↗B, A↘T	≥ 10			
		< 1			
D	P↗A, B↘T	≥ 10			
		< 1			
Electrically controlled failsafe version					
	Position	p _p [bar]	p _x [bar]	WV ²	VEL ³
W	Centered position defined	≥ 1	≥ 1	off	on
	Undefined	≥ 10	≥ 10	on	off
U	Centered position defined	≥ 1	≥ 1	off	on
	P↗B, A↘T	≥ 10	≥ 10	on	off
S	P↗A, B↘T	≥ 1	≥ 1	off	on
	P↗A, B↘T	≥ 10	≥ 10	on	off
X	Special versions upon request				



Argentina
Australia
Austria
Brazil
China
Finland
France
Germany
India

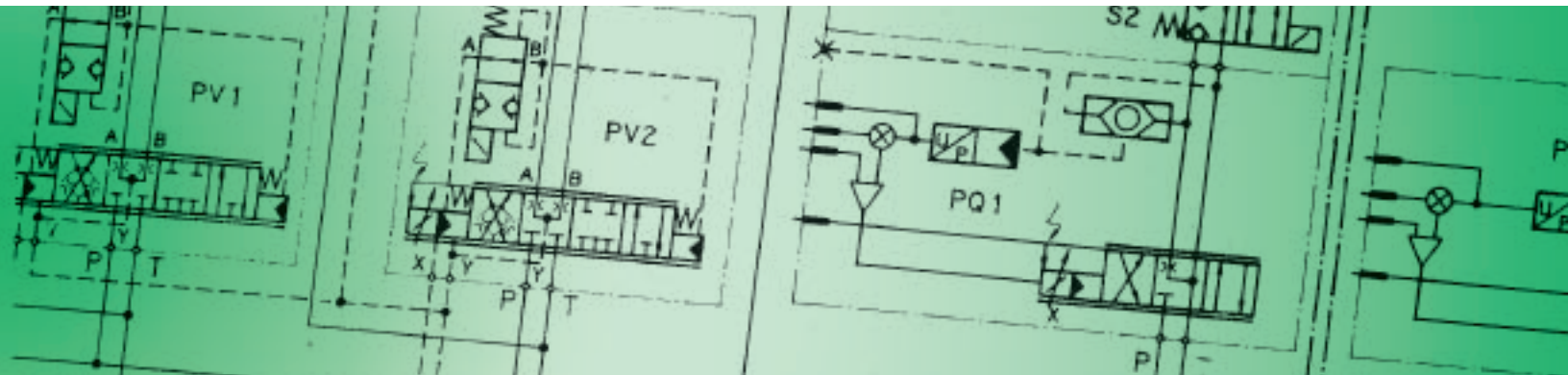

Ireland
Italy
Japan
Korea
Luxembourg
Norway
Philippines
Russia
Singapore
South Africa
Spain
Sweden
United Kingdom
USA

MOOG

Industrial Controls Division
Moog Inc., East Aurora, NY 14052-0018
Telephone: 716/655-3000
Fax: 716/655-1803
Toll Free: 1-800-272-MOOG
For the location nearest you,
contact www.moog.com/worldwide

D680 Series CDL6680 RevC 500-381 03/04